

Square Shape Instrument - PK Series



PK-60C



PK-80C



PK-100C



PK-120C

PK-series is a square type meter. 4 difference degree type for this square PK-series:120mm, 100mm, 80mm & 60mm. Panel cut dimension is conformity with JIS C 1103.

PK-series is a reliable meter be fully satisfied with standard JISC 1102-1~9 (conformity with IEC 60051-1) and adopt a most suitable operating principle for measuring object.

Our product improve with realibility special specification for overdue environmental conditions as cold resistance and tropical specification. Please consider to use our product on oversea such as the Frigid Zone and Tropical Zone.

FEATURES

- ▶ High quality and high performance meter.
- ▶ 4 types: 120mm, 100mm, 80mm, 60mm degree.
Select the most suitable type according to your panel space.
- ▶ Flame Retardant Material Meter can be manufacture by specify.
- ▶ Meter with knife-edge pointer also can be manufacture.
- ▶ Locked panel by 2 screws.

Square Shape Instrument - PK Series

TYPE CODE DESIGNATION

P (1) K - (2) (3) C (4) - (5)

(1) Type of measurand

Mark	Measurand	Operation Principle
M	DC current, voltage	Permanent magnet moving coil
X	DC receiving indicator	Permanent magnet moving coil
Y	AC receiving indicator	Rectifier
S	AC current, voltage	Moving iron
C	AC current, voltage	Rectifier, RMS value rectifier
W	AC watt-hour meter	Transducer
WVB	Var meter (balanced)	Transducer
WV	Var meter (unbalanced)	Transducer
PB	Power factor (balanced)	Transducer
P	Power factor (unbalanced)	Transducer
A	Frequency meter	Transducer

(2) Shape

Mark	Square Shape Meter
120	120 × 120
100	100 × 100
80	80 × 80
60	60 × 60

(4) Special Specifications

Mark	Specification
H	For SCR
C	Cycle Control
L	With Lamp
S	With Shield

(3) Structure

Mark	Structure
N	Transducer all-in-one type

(5) Kind of Circuit

Mark	Circuit
12	Single phase
13	Single phase 3-wire
33	3 phase 3-wire
34	3 phase 4-wire

Square Shape Instrument - PK Series

COMMON STANDARD SPECIFICATIONS

ITEM	SPECIFICATION	
Standard	JISC 1102: 2007 [Electric Indicating Meter Direct Acting Type]	
	JISC 1103 [Dimensions Electric Indicating Meter Switchboards]	
	IEC 60051-1 conformity	
Class	Refer to [List of PK series]	
Support system	Pivot system (Part of system is Taut band)	
Swing angle of pointer	86°	
Dimensions meter from front	PK-120C: 120×120mm	PK-80C: 80×80mm
	PK-100C: 100×100mm	PK-60C: 60×60mm
Length of scale	PK-20C: 95mm	PK-80C: 61mm
	PK-100C: 80mm	PK-60C: 45mm
Color of scale plate	White	
Pointer	Lance shape (Black)	
Installation posture	Vertical (⊥)	
Material panel	Iron & non-iron plate	
Thickness panel	10mm or less (6mm or less for PK-80C,PK-60C)	
Color of cover	Black (Munsell N1.5) Dark blue (Munsell 7.5BG 4/1.5)	
Material of case	Cover: Methacrylic acid resin molding (Antistatic treatment)	
Insulation resistance	Between electric circuit and outer case	DC500V, 50MΩ or more
Voltage test	Between electric circuit and outer case	AC3320V, between 5sec.
Safety requirements	Standard	JIS C 1010-1
	Insulation	Between electric circuit and outer case : Base of insulation
	Use	For indoor use (Cubicle etc.)
	High altitude	2000m or less
	Pollution	Pollution level 2
	Measure category	CAT III
	Max. circuit voltage	600V (Ammeter)
Operated temperature/ Humidity limit	-10~55°C, Average day temperature 40°C or less, 25~85% RH (Reference to steel ship rules ambient temperature 45°C)	
Storage temperature range	-20~70°C	

STANDARD SCALE DIVISION FOR LANCET SHAPE METER

Max. scale value (10 times)		1	1.5	2	2.5	3	4	5	6	7.5	8	9
Type	PK-120(N)C	20	30	40	25	30	40	25	30	37.5	40	45
	PK-100(N)C, PK-80C, PK-60C	20	30	20	25	30	20	25	30	15	16	18

STANDARD SCALE DIVISION FOR KNIFE SHAPE METER

Max. scale value (10 times)		1	1.5	2	2.5	3	4	5	6	7.5	8	9
Type	PK-120(N)C	50	75	40	50	60	80	50	60	75	80	45
	PK-100(N)C, PK-80C, PK-60C	50	30	20	50	30	40	50	30	37.5	40	45

Square Shape Instrument - PK series

COMMON SPECIAL SPECIFICATIONS (Please Specify)

ITEM		SPECIFICATION
Scale	Color line	Red, Green, Yellow (please specify)
	Extend scale	PCK, PSK: 2~5-time extend
	Color area (bar)	Red, Green, Yellow (please specify)
	Double scale	Please specify
	Double seal	Please specify
	Max. scale division	120 angle = 100 division, 100 angle = 80 division 80 angle = 60 division, 60 angle = 50 division
	Special scale	Please specify
Vibration proof specification	Vibration	Frequency 2~55Hz, 29.4m/s ²
	Shock	147m/s ² , 30-time
Tropical specification	Rust preventative, 「FOR TROPICS」 will display at the name plate	
Pointer	Knife shape (red), Rod shape (black), combine use with multiple scale etc.	
Control pointer	Lancet shape (red), 2 control pointer also possible to manufacture (red×2)	
Installation posture	Horizontal, or Inclined (specify the angle)	
Flame-retardant materials	Cover	Polycarbonate resin
Protection circuit of meter	Overcurrent	Specify necessary tolerated dose
	Overvoltage	Specify necessary tolerated dose
Extended part of scale	Voltmeter	Up to ±10%, ±20%, ±30% of central scale value 75% or more of scale length
	Ammeter	Up to 20% of upper limit value of effective measuring range 95% or more of scale length
		Up to 50% of upper limit value of effective measuring range 75% or more of scale length
For SCR control waves use	AC current, AC voltage, frequency	
For cycle control use	AC current, AC voltage (Rectifier Type)	
With lamp (Not for 120 angle)	DC6V (10mA), DC12, 24, 48V (6mA)	
Test report	Specify the useful frequency and number copies of report require	
Scale (single item)	Not JIS mark	
Color of cover	Specified color	
Terminal cover	Please consultation with us	
Others	Please consultation with us for special frequency	

ITEM TO SPECIFY WHEN MAKE PURCHASE

- 1).Type Name
- 2).Rated (Max. scale/ Input) ***1**
- 3).Color of cover
- 4).Terminal cover
- 5).Units
- 6).Options (Refer to Common Special Specification)
- 7).Test report (specify use frequency and number of copies require)

***1.** For max.scale value watt or var meter, please refer to List of Standard Max. Scale Value.
Please specify frequency of the power factor meter according to the specification.

Square Shape Instrument - PK Series

LIST OF PK SERIES

MODEL		PK-120(N)C		PK-100(N)C		PK-80C		PK-60C	
JIS MARK		KS-3b		KS-5a		KS-6a		KS-7	
Product	Principle	Type	Class	Type	Class	Type	Class	Type	Class
DC Ammeter	Moving coil	PMK-120C	1.5	PMK-100C	2.5	PMK-80C	2.5	PMK-60C	2.5
DC Voltmeter		PMK-120C	1.5	PMK-100C	2.5	PMK-80C	2.5	PMK-60C	2.5
DC Receiving Indicator	Moving coil	PXK-120C	1.5	PXK-100C	2.5	PXK-80C	2.5	PXK-60C	2.5
AC Receiving Indicator	Rectifier	PYK-120C	1.5	PYK-100C	2.5	PYK-80C	2.5	PYK-60C	2.5
AC Ammeter	Moving iron	PSK-120C	1.5	PSK-100C	2.5	PSK-80C	2.5	PSK-60C	2.5
AC Voltmeter		PSK-120C	1.5	PSK-100C	2.5	PSK-80C	2.5	PSK-60C	2.5
AC Ammeter	Rectifier	PCK-120C	1.5	PCK-100C	2.5	PCK-80C	2.5	PCK-60C	2.5
AC Voltmeter		PCK-120C	1.5	PCK-100C	2.5	PCK-80C	2.5	PCK-60C	2.5
Watt Meter	Single phase	PWK-120NC-12	1.5	PWK-100NC-12	2.5	PWK-80C-12	2.5	PWK-60C-12	2.5
	Single phase 3-wire	PWK-120NC-13	1.5	PWK-100NC-13	2.5	PWK-80C-13	2.5	PWK-60C-13	2.5
	3 phase	PWK-120NC-33	1.5	PWK-100NC-33	2.5	PWK-80C-33	2.5	PWK-60C-33	2.5
	3 phase 4-wire	PWK-120NC-34	1.5	PWK-100NC-34	2.5	PWK-80C-34	2.5	PWK-60C-34	2.5
Var Meter	Single phase	PWVK-120NC-12	1.5	PWVK-100NC-12	2.5-	PWVK-80C-12	2.5	PWVK-60C-12	2.5
	3 phase (balanced)	—	—	—	—	PWVBK-80C-33	2.5	PWVBK-60C-33	2.5
	3 phase (unbalanced)	PWVK-120NC-33	1.5	PWVK-100NC-33	2.5	PWVK-80C-33	2.5	PWVK-60C-33	2.5
	3 phase 4-wire	PWVK-120NC-34	1.5	PWVK-100NC-34	2.5	PWVK-80C-34	2.5	PWVK-60C-34	2.5
Power Factor Meter	Single phase	PPK-120NC-12	5.0	PPK-100NC-12	5.0	PPK-80C-12	5.0	PPK-60C-12	5.0
	3 phase (balanced)	PPBK-120NC-33		PPBK-100NC-33		PPBK-80C-33		PPBK-60C-33	
	3 phase (unbalanced)	PPK-120NC-33		PPK-100NC-33		PPK-80C-33		PPK-60C-33	
	3 phase 4-wire (balanced)	PPBK-120NC-34		PPBK-100NC-34		PPBK-80C-34		PPBK-60C-34	
	3 phase 4-wire (unbalanced)	PPK-120C-34		PPK-100C-34		PPK-80C-34		PPK-60C-34	
Frequency Meter	Transducer	PAK-120C	1.0	PAK-100C	1.0	PAK-80C	1.0	PAK-60C	1.0

► Keep in mind please, Transducer type meter does transitional indication at voltage input start.

DC Ammeter (Moving Coil Type) - PMK

AMMETER

Max. scale value	Approx. Internal Resistance Or Drop Voltage	Accessory	
	PMK-120C, 100C, 80C, 60C		
25μA	2.26kΩ	-	
50μA	1.3kΩ		
100μA ⁽³⁾	2.1kΩ		
200μA	1kΩ		
500μA	240Ω		
1mA	120Ω		
2mA	11Ω		
5mA	12Ω		
10mA	3.2Ω		
20mA	2.8Ω		
50mA~30A	60mV		
30A~10kA ⁽¹⁾	60mV		Shunt ⁽²⁾

▶ Meter value up until 1Ω can manufacture. Please specify your value when lead wire resistance value is over 0.07Ω.

Lead Wire Resistance Value

Cross Section (mm ²)	Annealed Copper (Ω/m)	Remarks
1.25	0.0165	JIS C 3307 (IV)
2.0	0.00924	JIS C 3317 (HIV)
3.5	0.00520	Twist wire

▶ Meter built-in variable resistance for external resistance correction also can manufacture.

▶ Meter both deflections also can manufacture.

Note:

- ⁽¹⁾ Please use external shunt (60mV) for scale value 30A or more. Shunt 50mV & 100mV also can manufacture.
- ⁽²⁾ Lead wire for shunt is not attached. Standard lead wire resistance is 0.07Ω (1.25mm²)
- ⁽³⁾ PMK-120C: Internal resistance is 1.1kΩ when 100μA.

Connection Diagram

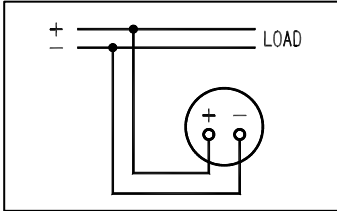

Ammeter

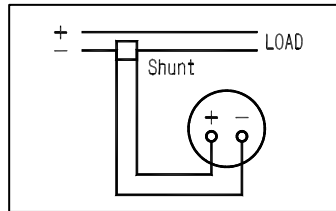

Ammeter external with shunt

Dimensions

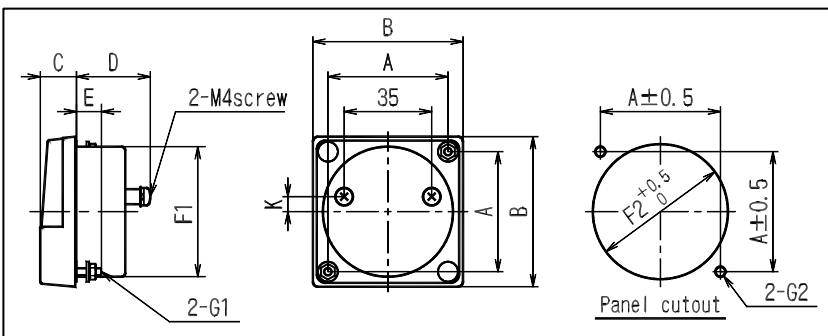

Type	A	B	C	D	E	F1	F2	G1	G2	K	weight (g)
PMK-120C	100	123	20	41.5	15	110Φ	112ΦHole	M5 Screw	7ΦHole	0	350
PMK-100C	80	100	16	31	15	85Φ	87ΦHole	M4 Screw	5.5ΦHole	0	180
PMK-80C	64	80	14.5	29.5	10	65Φ	67ΦHole	M3 Screw	4ΦHole	0	125
PMK-60C	48	60	14.5	29.5	10	52Φ	54ΦHole	M3 Screw	4ΦHole	6	90

DC Voltmeter (Moving Coil Type) - PMK

VOLTMETER

Max. Scale Value	Consumption Current	Accessory
	PMK-120C, 100C, 80C, 60C	
50mV~900mV	4mA	
1V~600V ⁽¹⁾⁽²⁾	1mA	
750V/1mA~25kV/1mA ⁽¹⁾⁽²⁾	1mA	Series Resistor

Note:

- ⁽¹⁾ Internal resistance up until 10kΩ/V can manufacture for voltmeter scale 3V or more.
- ⁽²⁾ Please use external series resistor (1mA) for scale value 600V or more.

- ▶ Meter both deflections can manufacture.
- ▶ Protection overvoltage for voltmeter more than 500mV also can manufacture.

Connection Diagram

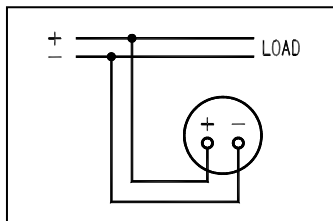

Voltmeter

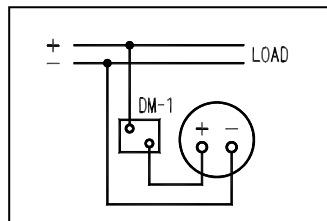

Voltmeter external with series resistor (DM-1)

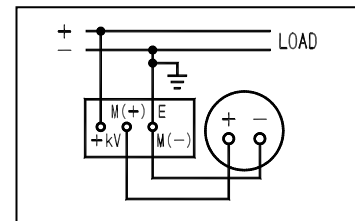

Voltmeter external with series resistor (DM-2~25)

Dimensions

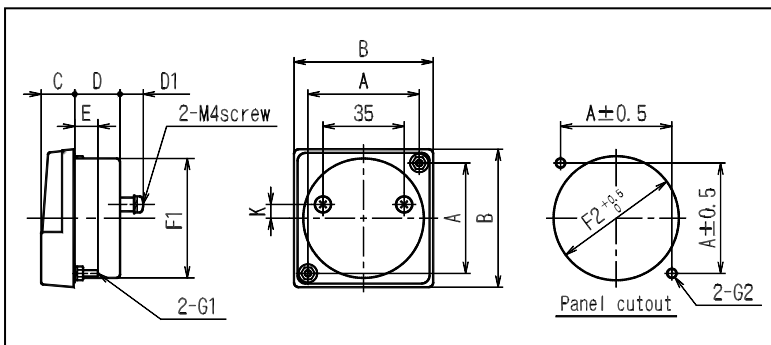

Type	A	B	C	D	E	F1	F2	G1	G2	K	weight (g)
PMK-120C	100	123	20	41.5	15	110Φ	112ΦHole	M5 Screw	7ΦHole	0	350
PMK-100C	80	100	16	31	15	85Φ	87ΦHole	M4 Screw	5.5ΦHole	0	180
PMK-80C	64	80	14.5	29.5	10	65Φ	67ΦHole	M3 Screw	4ΦHole	0	125
PMK-60C	48	60	14.5	29.5	10	52Φ	54ΦHole	M3 Screw	4ΦHole	6	90

DC Receiving Indicator Meter (Moving Coil Type) - P XK

Receiving indicator meter for ammeter or voltmeter can be used to receive electrical signals from detectors or transmitters, and measure various physical quantities, electric power, power factor, and frequency. Scale values and input electrical quantities can be manufactured to specifications.

For example:

Scale 100% **Input electric DC3V**
Scale 0~2MPa **Input electric DC4~20mA**

Meters with built-in variable resistors for input voltage correction (standard $\pm 20\%$) can also be manufactured.

DC RECEIVING INDICATOR

Input Electrical Quantity	Approx. Internal Resistance	Input Electrical Quantity	Consumption Current
	PXK-120C, 100C, 80C, 60C		PXK-120C, 100C, 80C, 60C
100 μ A ⁽¹⁾	2.1K Ω	1V	1mA ⁽³⁾
500 μ A	240 Ω	2V	
1mA	120 Ω	1~5V ⁽²⁾	
2mA	11 Ω	5V	
5mA	12 Ω	10V	
10mA	3.2 Ω	20V	
20mA	2.8 Ω	50V	
4~20mA ⁽²⁾	2.8 Ω	∞	
10~50mA ⁽²⁾	1.5 Ω	300V	

Note:

⁽¹⁾ PXK-120C: Internal resistance is 1.1k Ω when 100 μ A.

⁽²⁾ Input bias for 1V, 4mA scale zero position adjustment is necessary for meters receiving input electrical signals with bias DC1-5V, DC4-20mA etc.

⁽³⁾ Consumption current for VR internal meter is 1mA.

► Meters with both deflections can be manufactured.

Connection Diagram

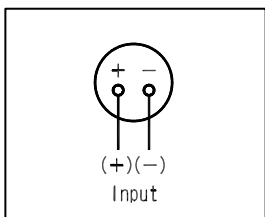

DC Receiving Indicator

Dimensions

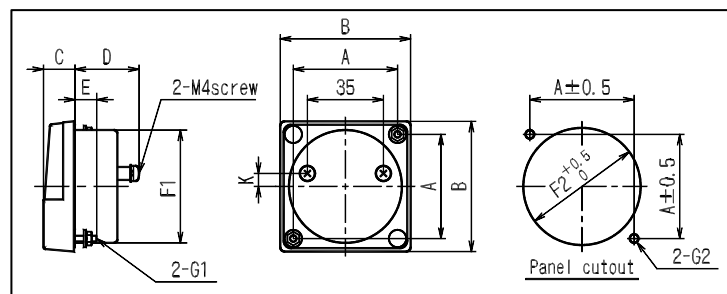

Type	A	B	C	D	E	F1	F2	G1	G2	K	weight (g)
PXK-120C	100	123	20	41.5	15	110 Φ	112 Φ Hole	M5 Screw	7 Φ Hole	24	350
PXK-100C	80	100	16	31	15	85 Φ	87 Φ Hole	M4 Screw	5.5 Φ Hole	15	180
PXK-80C	64	80	14.5	29.5	10	65 Φ	67 Φ Hole	M3 Screw	4 Φ Hole	0	125
PXK-60C	48	60	14.5	29.5	10	52 Φ	54 Φ Hole	M3 Screw	4 Φ Hole	6	90

AC Receiving Indicator Meter (Rectifier Type) - PYK

Receiving indicator meter for ammeter or voltmeter can be used to receive electrical signals from detectors or transmitters, and measure various physical quantities, electric power, power factor, and frequency. Scale values and electrical input can be specified.

For example:

Scale 100% **Input electric DC3V**
Scale 0~2MPa **Input electric DC4~20mA**

Meters with built-in variable resistors for input voltage correction (standard $\pm 20\%$) can also be manufactured.

AC RECEIVING INDICATOR

Input Electrical Quantity	Approx. Internal Resistance or Consumption VA	Input Electrical Quantity	Consumption Current
	PYK-120C, 100C, 80C, 60C		PYK-120C, 100C, 80C, 60C
100 μ A	5k Ω	3V 5 300V	1mA
500 μ A	1.5k Ω		
1mA	800 Ω		
3mA	350 Ω		
5mA	300 Ω		
10mA	0.5VA		
20mA			

Connection Diagram

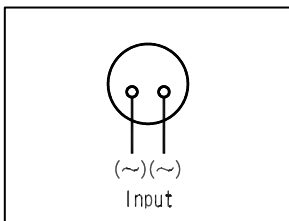

AC Receiving Indicator

Dimensions

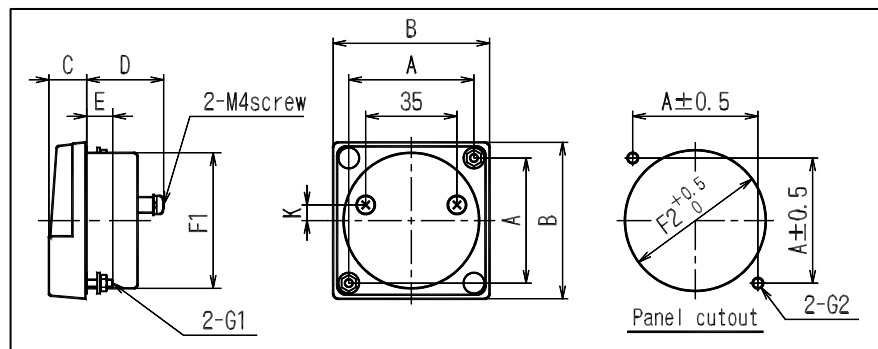

Type	A	B	C	D	E	F1	F2	G1	G2	K	weight (g)
PYK-120C	100	123	20	41.5	15	110 Φ	112 Φ Hole	M5 Screw	7 Φ Hole	24	350
PYK-100C	80	100	16	31	15	85 Φ	87 Φ Hole	M4 Screw	5.5 Φ Hole	15	180
PYK-80C	64	80	14.5	29.5	10	65 Φ	67 Φ Hole	M3 Screw	4 Φ Hole	0	125
PYK-60C	48	60	14.5	29.5	10	52 Φ	54 Φ Hole	M3 Screw	4 Φ Hole	6	90

AC Ammeter (Moving Iron Type) - PSK

AC AMMETER

Nomal Scale	Extended Scale				Consumption VA	Note: (1) Please use external current transformer (CT) 5A (0.1A, 1A) for scale 30A or more and scale 600V or more in circuit voltage. ► Meter for 400Hz use can manufacture. Please specify. For SCR Control Waveform Meter SCR waveform input (Distortion waveform) also can manufacture. Type name: PSK-□CH
Max. scale value	2-time	3-time	4-time	5-time	PSK-120C, 100C, 80C, 60C	
100mA	200mA	300mA	400mA	500mA	1VA	
500mA	1A	1.5A	2A	2.5A		
1A	2A	3A	4A	5A		
3A	6A	9A	12A	15A		
5A	10A	15A	20A	25A		
7.5A	15A	22.5A	30A	37.5A		
10A	20A	30A	40A	50A		
15A	30A	45A	60A	75A		
20A	40A	60A	80A	100A		
30A	60A	90A	120A	150A		
5/5A	10A	15A	20A	25A	1VA	
?	?	?	?	?		
10k/ 5A (1)	20kA	30kA	40kA	50kA		

Connection Diagram

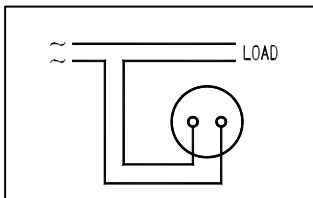

Ammeter

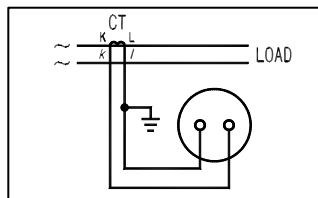

Ammeter external with CT

Dimensions

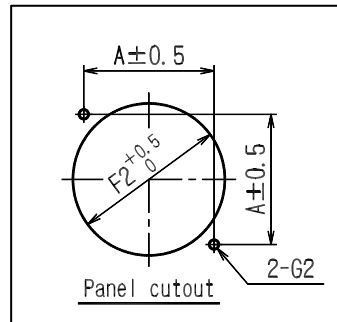
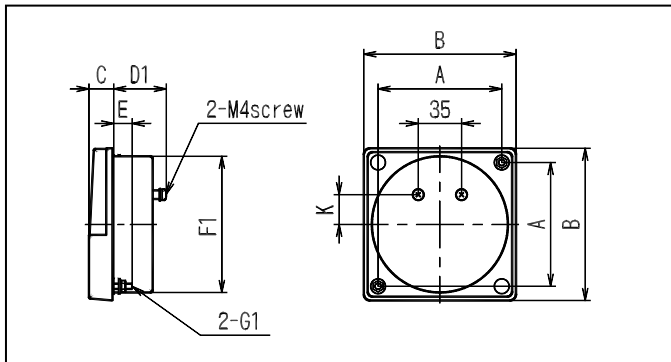

For ammeter & voltmeter use

Type	A	B	C	D1	D2	E	F1	F2	G1	G2	K	weight (g)
PSK-120C	100	123	20	41.5	48	15	110Φ	112ΦHole	M5 Screw	7ΦHole	24	370
PSK-100C	80	100	16	41.5	48	15	85Φ	87ΦHole	M4 Screw	5.5ΦHole	15	260
PSK-80C	64	80	14.5	37.5	45.5	10	65Φ	67ΦHole	M3 Screw	4ΦHole	0	165
PSK-60C	48	60	14.5	37.5	45.5	10	52Φ	54ΦHole	M3 Screw	4ΦHole	6	130

Voltmeter (Moving Iron Type) - PSK

VOLTMETER

Max. Scale Value	Consumption VA		Accessory (Series Resistor)
	PSK-120C, 100C, 80C, 60C		
50V 100V	5VA		
150V 300V	5VA		
600V	10VA		DM-41 ⁽¹⁾
600/150V ⁽²⁾ ~ 550k/150V	5VA		

Note:

- (1) Use external DM-41 for scale from 301V~600V.
- (2) Use external voltage transformer (VT) 150V for scale 600V or more.

For SCR Control Waveform

Meter SCR waveform input (Distortion Waveform) also can manufacture.

Type Name: PSK-□CH

Connection Diagram

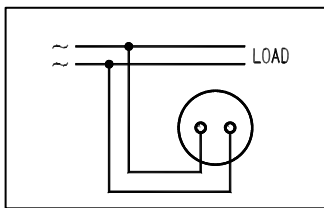

Voltmeter

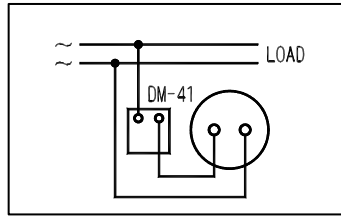

Voltmeter external with series resistor

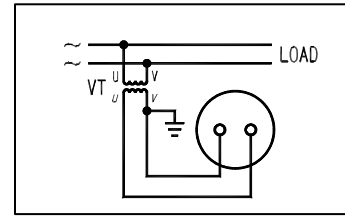

Voltmeter external with VT

Dimension

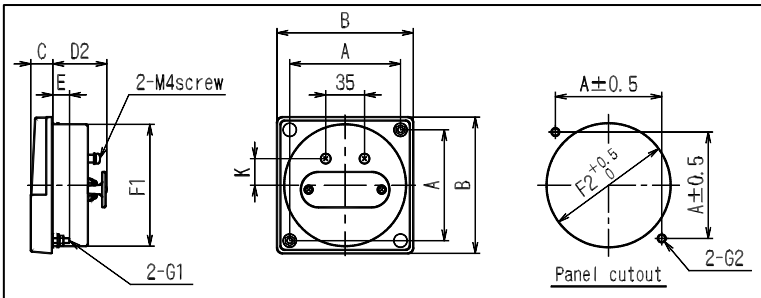

For voltmeter PSK-120C, 100C

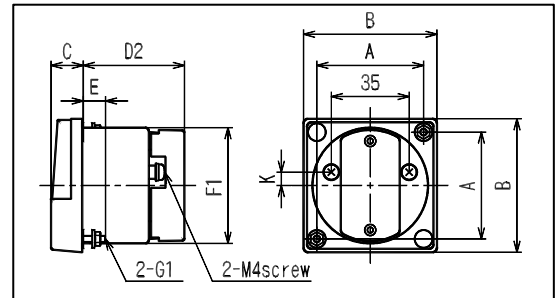

For voltmeter PSK-80C, 60C

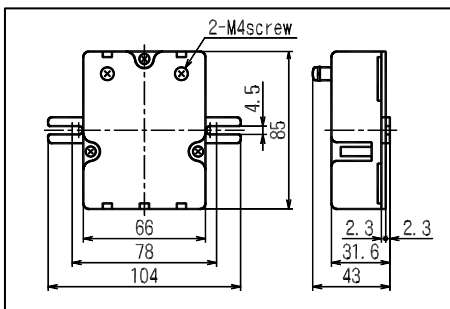

Dimension for DM-41

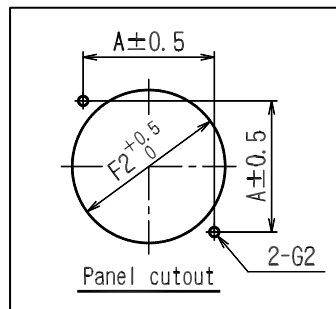

For ammeter & voltmeter use

Type	A	B	C	D1	D2	E	F1	F2	G1	G2	K	weight(g)
PSK-120C	100	123	20	41.5	48	15	110Φ	112ΦHole	M5 Screw	7ΦHole	24	370
PSK-100C	80	100	16	41.5	48	15	85Φ	87ΦHole	M4 Screw	5.5ΦHole	15	260
PSK-80C	64	80	14.5	37.5	45.5	10	65Φ	67ΦHole	M3 Screw	4ΦHole	0	165
PSK-60C	48	60	14.5	37.5	45.5	10	52Φ	54ΦHole	M3 Screw	4ΦHole	6	130

AC Ammeter (Rectifier Type) - PCK

AMMETER

Max. Scale Value	Approx. Internal Resistance or Consumption VA	Accessory
	PCK-120C, 100C, 80C, 60C	
100μA	5kΩ	
500μA	1.5kΩ	
1mA	800Ω	
3mA	350Ω	
5mA ⁽²⁾	300Ω	
10mA ~ 300mA ⁽²⁾	0.5VA	
350mA ~ 100A ⁽¹⁾	1VA	MR-CTN

Note:

(1) Please use external current transformer (CT) 5A (0.1A, 1A) for scale 100A or more & 600V or more in circuit voltage.

(2) Protection overcurrent for ammeter 100mA or less can manufacture.

▶ Extended Scale also can manufacture. (External with AT-62M, input until 15A only, dimensions refer to pg.19)

▶ For High harmonic wave use, we can manufacture until 10kHz, please specify.

For Cycle Control Waveform Meter

Please use cycle control for cycle control waveform type.

Type Name: PCTK-□CC, External with AT-62MEC.

For Distorted Waveform Meter (Approx. RMS value rectifier method)

Please keep in mind, that standard rectifier type will be affected by waveform distortion.

Please use approx. RMS value rectifier method for third harmonics mixed with waveform and SCR waveform.

Type Name: PCTK-□C, External with AT-62ME

Dimension

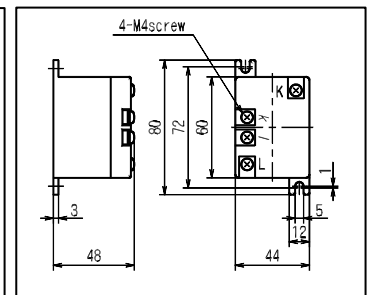
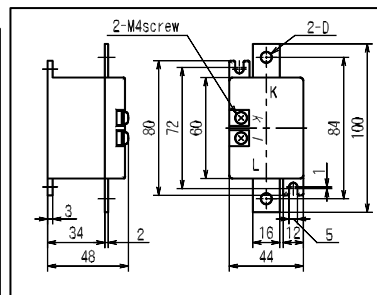
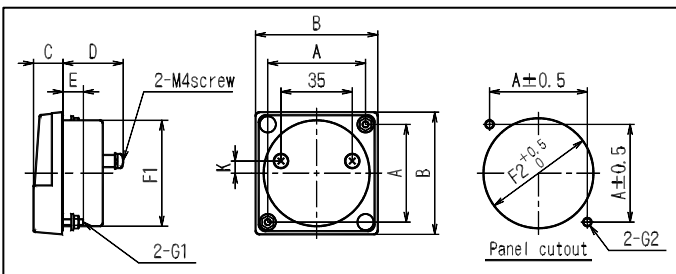

MR-CTN (30~100A/20mA)

MR-CTN (0.35~25A/10mA)

Connection Diagram

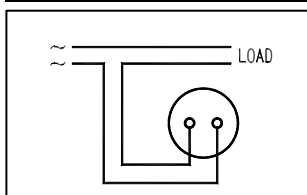

Ammeter

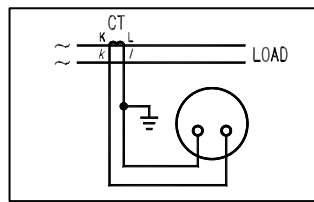

Ammeter external with CT or MR-CTN

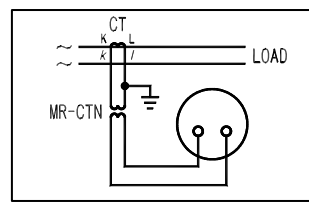

Ammeter external with CT and MR-CTN

Current (A)	D
30~70	Φ6.5
75~100	Φ8.5

Type	A	B	C	D	E	F1	F2	G1	G2	K	weight (g)
PCK-120C	100	123	20	41.5	15	110Φ	112ΦHole	M5 Screw	7ΦHole	0	350
PCK-100C	80	100	16	31	15	85Φ	87ΦHole	M4 Screw	5.5ΦHole	0	180
PCK-80C	64	80	14.5	29.5	10	65Φ	67ΦHole	M3 Screw	4ΦHole	0	125
PCK-60C	48	60	14.5	29.5	10	52Φ	54ΦHole	M3 Screw	4ΦHole	6	90

Voltmeter (Rectifier Type) - PCK

VOLTMETER

Max. Scale Value	Consumption Current	Accessory
	PCK-120C, 100C, 80C, 60C	
3V~600V	1mA ⁽²⁾	—
750V~25kV ⁽¹⁾	1mA ⁽²⁾	Series Resistance

Note:

⁽¹⁾ Please use external series resistor (1mA) for scale value 600V or more. (Please refer to Instrument accessory for series resistor size)

⁽²⁾ Internal resistance up until 10kΩ/V can manufacture.

► For High harmonic wave use, we can manufacture until 10kHz, please specify.

For Cycle Control Waveform Meter

Please use cycle control for cycle control waveform type.

Type Name: PCTK-□CC, External with VT-62MEC.

For Distorted Waveform Meter (Approx. RMS value rectifier method)

Keep in mind please, that standard rectifier type will be affected by waveform distortion.

Please use approx. RMS value rectifier method for third harmonics mixed with waveform and SCR waveform.

Type Name: PCTK-□C, External with VT-62ME

Connection Diagram

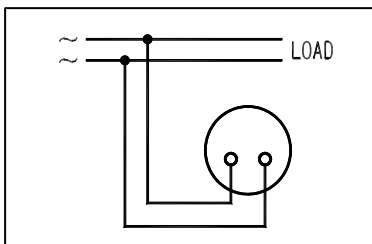

Voltmeter

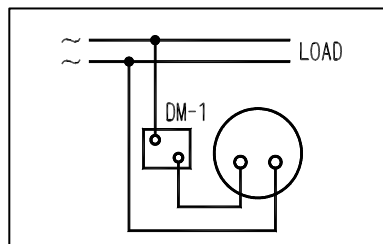

Voltmeter external with series resistor (DM-1)

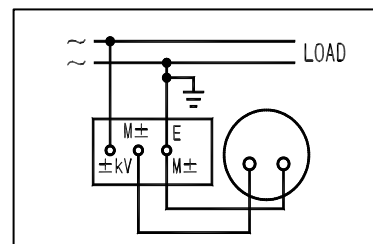

Voltmeter external with series resistor (DM-2~25)

Dimensions

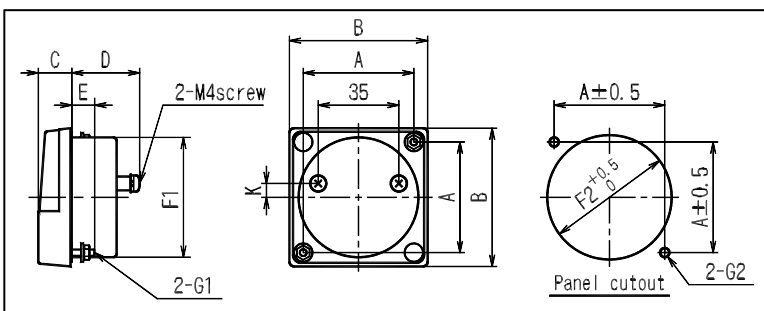

Type	A	B	C	D	E	F1	F2	G1	G2	K	weight (g)
PCK-120C	100	123	20	41.5	15	110Φ	112ΦHole	M5 Screw	7ΦHole	0	350
PCK-100C	80	100	16	31	15	85Φ	87ΦHole	M4 Screw	5.5ΦHole	0	180
PCK-80C	64	80	14.5	29.5	10	65Φ	67ΦHole	M3 Screw	4ΦHole	0	125
PCK-60C	48	60	14.5	29.5	10	52Φ	54ΦHole	M3 Screw	4ΦHole	6	90

Watt-hour Meter (Transducer Type) - PWK

WATTHOUR METER (Transducer All-In-One Type) ⁽¹⁾

Application	Type	Rating ⁽²⁾	Consumption VA		Accessory
			Voltage side	Current side	
Single phase	PWK-120NC-12	110V, 5A (1A)	2VA	1VA	—
	PWK-100NC-12	220V, 5A (1A)	3.5VA	1VA	
Single phase 3-wire	PWK-120NC-13 PWK-100NC-13	110V, 5A (1A)	2VA	1VA	—
3 phase 3-wire	PWK-120NC-33	110V, 5A (1A)	2VA	1VA	—
	PWK-100NC-33	220V, 5A (1A)	3.5VA	1VA	
3 phase 4-wire	PWK-120NC-34	110/√3V, 5A (1A)	2VA	1VA	—
	PWK-100NC-34	220/√3V, 5A (1A)	3.5VA	1VA	

Note:

- (1) Please refer to (page 18) for manufacture limit and max. scale value.
- (2) Please use external CT, 5A(1A) or VT, 110V respectively if above rating is exceeds.
Usable voltage range for 110V: 90~130V & 220V: 180~260V

Connection Diagram

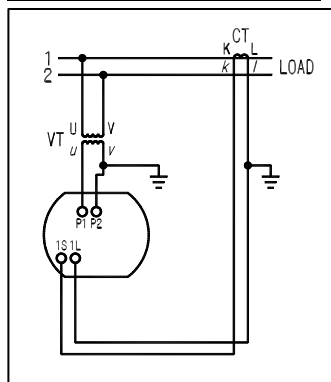

Single phase watt-hour meter

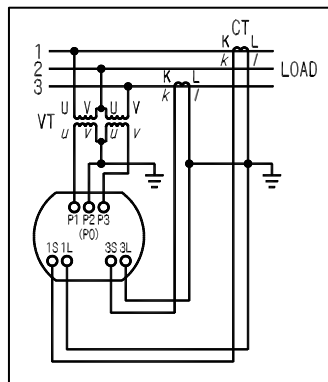

Single phase 3-wire watt-hour meter
3 phase 3-wire watt-hour meter

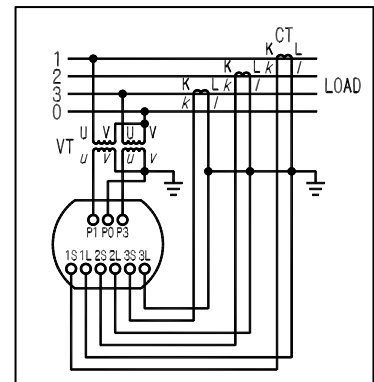

3 phase 4-wire watt-hour meter

Dimensions

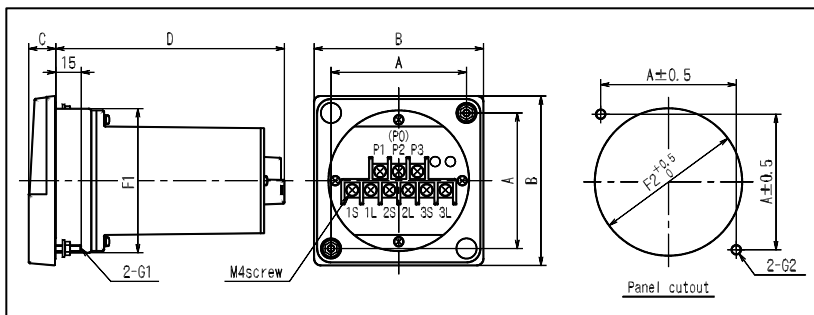

Type	A	B	C	D	F1	F2	G1	G2	weight (g)
PWK-120NC	100	123	20	145.5	110Φ	112ΦHole	M5 Screw	7ΦHole	510
PWK-100NC	80	100	16	135	85Φ	87ΦHole	M4 Screw	5.5ΦHole	400

Var Meter (Transducer Type) - PWVK

VAR METER (Transducer All-In-One Type) ⁽¹⁾

Application	Type	Rating ⁽²⁾	Consumption VA		Accessory
			Voltage	Current	
Single phase	PWVK-120NC-12	110V, 5A (1A)	2VA	1VA	—
	PWVK-100NC-12	220V, 5A (1A)	3.5VA	1VA	
3 phase 3-wire	PWVK-120NC-33	110V, 5A (1A)	2VA	1VA	—
	PWVK-100NC-33	220V, 5A (1A)	3.5VA	1VA	
3 phase 4-wire	PWVK-120NC-34	110V, 5A (1A)	2VA	1VA	—
	PWVK-100NC-34	220V, 5A (1A)	3.5VA	1VA	

Note:

⁽¹⁾ Please refer to (page 18) for manufacture limit and max. scale value.

Standard scale: Lead □ var ~ 0 ~ Lag □ var

⁽²⁾ Please use external CT, 5A(1A) or VT, 110V respectively if above rating is exceeds.

Usable voltage range for 110V: 90 ~ 130V & 220V: 180 ~ 260V

Connection Diagram

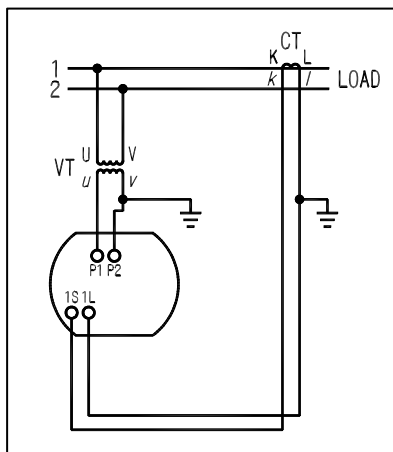

Single phase var meter

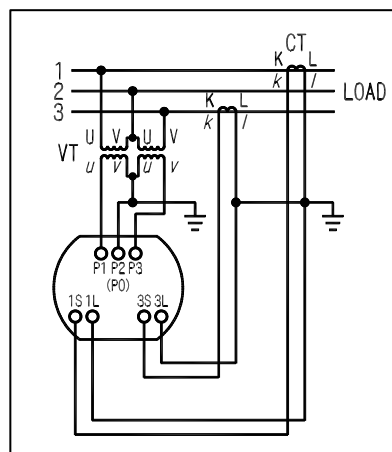

3 phase 3-wire var meter

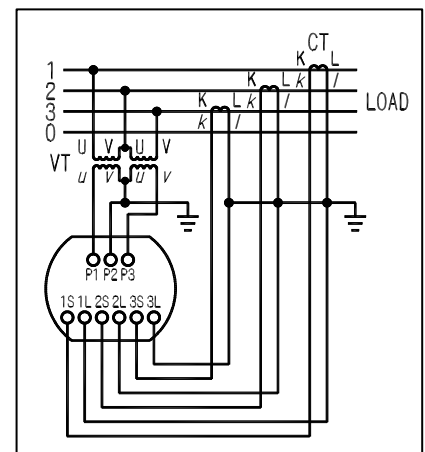

3 phase 4-wire var meter

Dimensions

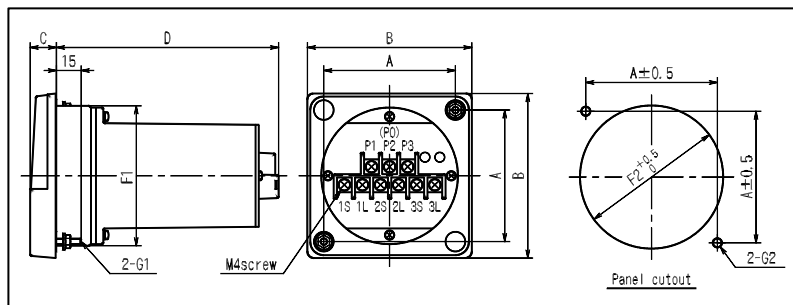

Type	A	B	C	D	F1	F2	G1	G2	weight (g)
PWVK-120NC	100	123	20	145.5	110Φ	112ΦHole	M5 Screw	7ΦHole	510
PWVK-100NC	80	100	16	135	85Φ	87ΦHole	M4 Screw	5.5ΦHole	400

Watt-hour Meter (Transducer Type) - PWK

WATTHOUR METER (External with Transducer Type) ⁽¹⁾

Application	Type	Rating ⁽²⁾	Consumption VA		Accessory (Transducer)
			Voltage	Current	
Single phase	PWK-80C-12 60C-12	110V, 5A (1A)	2VA	1VA	WT-62M-12
		220V, 5A (1A)	3.5VA	1VA	
Single phase 3-wire	PWK-80C-13 60C-13	110V, 5A (1A)	Each phase 2VA	Each phase 1VA	WT-83M-13
3 phase	PWK-80C-33 60C-33	110V, 5A (1A)	Each phase 2VA	Each phase 1VA	WT-83M-33
		220V, 5A (1A)	Each phase 3.5VA	Each phase 1VA	
3 phase 4-wire ⁽³⁾	PWK-80C-34 60C-34	110/√3V, 5A (1A)	Each phase 1.5VA	Each phase 1VA	WT-83M-34
		220/√3V, 5A (1A)	Each phase 3VA	Each phase 1VA	

Note:

(1) Please refer to (page 18) for manufacture limit and Max. scale value.

(2) If above rating is exceeds, please use external CT, 5A(1A) or VT, 110V respectively.

Usable voltage range: 110V: 90~130V; 220V: 180~260V

(3) 3 phase 4-wire is voltage balanced.

► For High harmonic ware use, please specify the frequency.

For SCR Wareform Meter

PWK-□CH-□

Aux. power is necessary. (3 phase 4-wire can not manufacture)

Connection Diagram

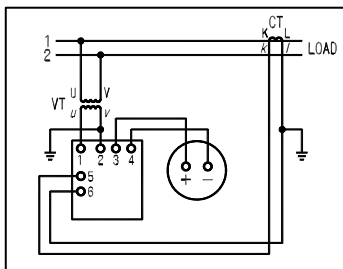

Single phase watt-hour meter external with WT-62M12

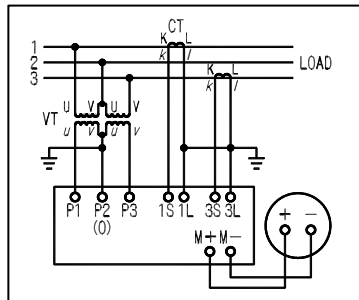

Single phase 3-wire & 3 phase watt-hour meter external with WT-83M13/ 33

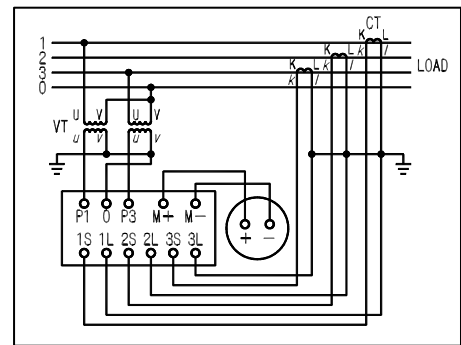

3 phase 4-wire watt-hour meter WT-83M34

Dimensions

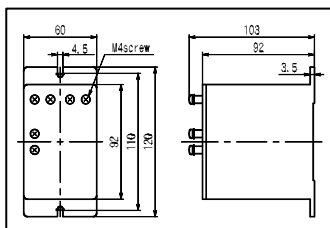
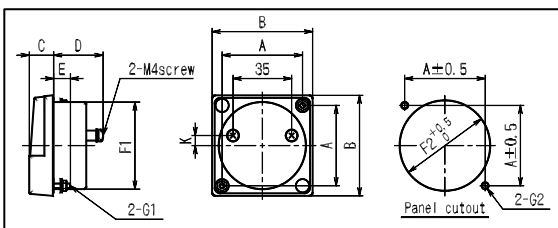

For Type: □T62M - □ - □

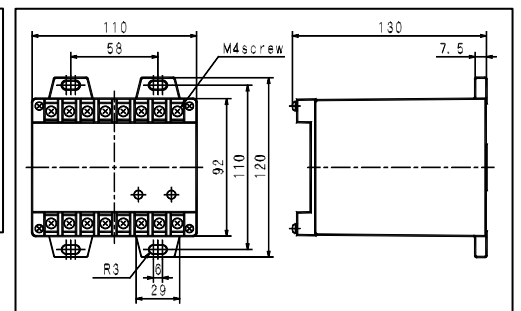

For Type: □T - 83M - □

Type	A	B	C	D	E	F1	F2	G1	G2	K	weight (g)
PWK-80C	64	80	14.5	29.5	10	65Φ	67ΦHole	M3 Screw	4ΦHole	0	1000
PWK-60C	48	60	14.5	29.5	10	52Φ	54ΦHole	M3 Screw	4ΦHole	6	950

Var Meter (Transducer Type) - PWVK

VAR METER (External with Transducer Type) ⁽¹⁾

Application	Type	Rating ⁽²⁾	Consumption VA		Accessory (Transducer)
			Voltage	Current	
Single phase ⁽³⁾	PWVK-80C-12 60C-12	110V, 5A (1A)	2VA	1.5VA	WVT-62M-12
		220V, 5A (1A)	3.5VA	1.5VA	
3 phase (balanced) ⁽⁴⁾	PWVBK-80C-33 60C-33	110V, 5A (1A)	Each phase 2VA	Each phase 1VA	WVBT-83M-33
		220V, 5A (1A)	Each phase 3.5VA	Each phase 1VA	
3 phase (unbalanced) ⁽⁴⁾	PWVK-80C-33 60C-33	110V, 5A (1A)	Each phase 2VA	Each phase 1VA	WVT-83M-33
		220V, 5A (1A)	Each phase 3.5VA	Each phase 1VA	
3 phase 4-wire (unbalanced) ⁽⁴⁾⁽⁵⁾	PWVK-80C-34 60C-34	110V, 5A (1A)	Each phase 2VA	Each phase 1VA	WVT-83M-34
		220V, 5A (1A)	Each phase 3.5VA	Each phase 1VA	

Note:

- (1) Please refer to (page 18) for Manufacture limit and Max. scale value.
Standard scale: Lead \square var \sim 0 \sim Lag \square var
- (2) If above rating is exceeds,
Please use external CT, 5A(1A) or VT, 110V respectively.
Usable voltage range for 110V: 90 \sim 130V & 220V: 180 \sim 260V
- (3) Please specify the frequency (50Hz or 60Hz) for single phase circuit.
- (4) Please use 3 phase, 3 phase 4-wire in positive phase sequence.
- (5) 3 phase 4-wire is voltage balanced.

Connection Diagram

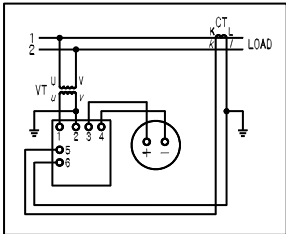

Single phase var meter external with WVT-62M-12

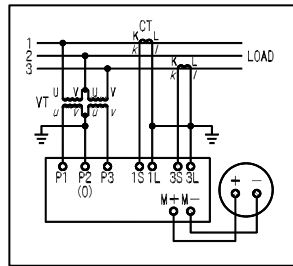

Single phase 3-wire & 3 phase var meter external with WVT-83M-13/ 33

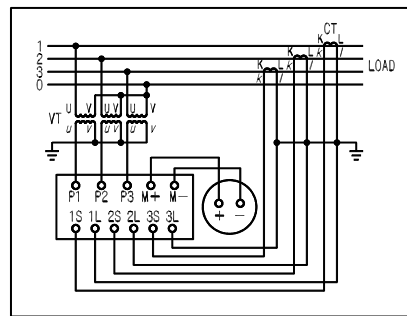

3 phase 4-wire var meter external with WVT-83M-34

Dimensions

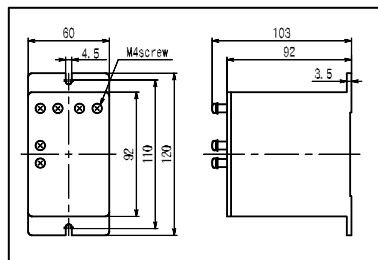
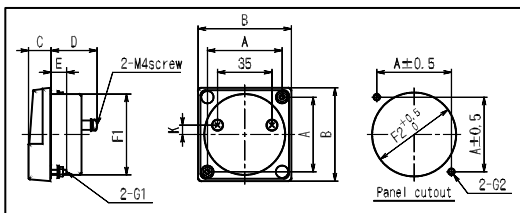

For Type: \square T62M - \square - \square

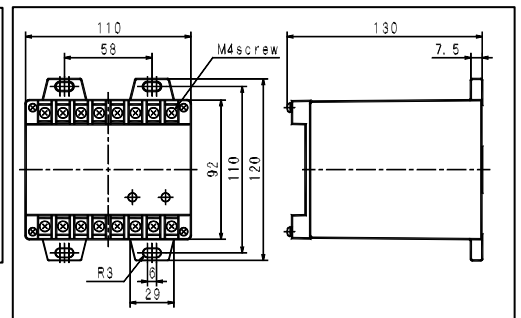

For Type: \square T - 83M - \square

Type	A	B	C	D	E	F1	F2	G1	G2	K	weight (g)
PWV(B)K-80C	64	80	14.5	29.5	10	65 Φ	67 Φ Hole	M3 Screw	4 Φ Hole	0	1000
PWV(B)K-60C	48	60	14.5	29.5	10	52 Φ	54 Φ Hole	M3 Screw	4 Φ Hole	6	950

Watt-hour Meter & Var Meter (Transducer Type) – PWK / PWVK

MANUFACTURABLE RANGE MAX. SCALE VALUE FOR INTRINSIC METER

Manufacturable range will be limited where intrinsic max. scale value is within the scope as shown in the right list. But in the case, the meter is used with external CV or VT, max. scale value will be calculated as following formula:

$$\frac{\text{Intrinsic Max. scale value}}{\text{Max. scale value}} = \frac{\text{Max. scale value}}{\text{VT ratio} \times \text{CT ratio}}$$

Type Name	Rating			Manufacturable Intrinsic Max. Scale Value	
				Watt-hour Meter	Var Meter
Single phase	110V / 5A(1A)			350~600W (70~120W)	350~600var (70~120var)
	220V / 5A(1A)			700~1200W (140~240W)	700~1200var (140~240var)
Single phase 3-wire	110V / 5A(1A)			600~1200W (120~240W)	—
3 phase 3-wire	110V / 5A(1A)			600~1200W (120~240W)	600~1200var (120~240var)
	220V / 5A(1A)			1200~2400W (240~480W)	1200~2400var (240~480var)
3 phase 4-wire	Line	Phase	Current	—	—
	110V	110/√3V	5A(1A)	600~1200W (120~240W)	600~1200var (120~240var)
	220V	220/√3V	5A(1A)	1200~2400W (240~480W)	1200~2400var (240~480var)

REFERENCE LIST FOR STANDARD MAX. SCALE VALUE THREE PHASE WATTMETER

The following table is the standard of 3 phase wattmeter.

This table also applies for 3 phase 4-wire wattmeter, single phase 3-wire watt-hour meter and var meter.

Standard for single phase wattmeter calculation is: the listed value × 1/2

Line vol. CT ratio	6600V (VT6600/110V)			3300V (VT3300/110V)			440V (VT440/110V)			220V			110V		
	kW 60	kW 50	kW 40	kW 30	kW 25	kW 20	kW 4	kW 5	kW 3	kW 2	kW 1.5	kW 1.2	kW 1	kW 0.8	kW 0.6
5/5A	90	75	60	45	40	30	6	5	4	3	2.5	2	1.5	1.2	1
7.5/5A	120	100	80	60	50	40	8	7.5	6	4	3	2.5	2	1.5	1.2
10/5A	200	150	120	100	75	60	12	10	8	6	5	4	3	2.5	2
15/5A	240	200	150	120	100	80	15	-	12	8	6	5	4	3	2.5
20/5A	300	250	200	150	120	100	20	-	15	10	8	7.5	5	4	3
25/5A	400	300	240	200	150	120	24	-	20	12	10	8	6	5	4
30/5A	480	400	300	240	200	150	30	-	24	15	12	10	8	7.5	5
40/5A	600	500	400	300	250	200	40	-	30	20	15	12	10	8	6
50/5A	750	600	480	400	300	240	48	-	40	24	-	20	12	10	8
60/5A	900	750	600	450	400	300	60	50	40	30	25	20	15	12	10
75/5A	1200	1000	800	600	500	400	80	75	60	40	30	25	20	15	12
100/5A	2000	1500	1200	1000	750	600	120	100	80	60	50	40	30	25	20
150/5A	2400	2000	1500	1200	1000	800	150	-	120	80	60	50	40	30	25
200/5A	3000	2500	2000	1500	1200	1000	200	-	150	100	80	75	50	40	30
250/5A	4000	3000	2400	2000	1500	1200	240	-	200	120	100	80	60	50	40
300/5A	4000	-	3000	2000	-	1500	300	250	200	150	120	100	75	60	50
350/5A	4800	4000	3000	2400	2000	1500	300	-	250	150	120	100	80	75	50
400/5A	6000	5000	4000	3000	2500	2000	400	300	250	200	150	120	100	75	60
450/5A	6000	5000	4000	3000	2500	2000	400	-	300	200	150	120	100	75	60
500/5A	7500	6000	4800	4000	3000	2400	500	-	400	240	-	200	120	100	70
600/5A	9000	7500	6000	4500	4000	3000	650	500	400	300	250	200	150	120	100
750/5A	10MW	8000	7500	5000	-	4000	700	600	500	300	250	200	150	120	100
800/5A	12MW	10MW	8000	6000	5000	4000	800	750	600	400	300	250	200	150	120
1000/5A	15MW	12MW	10MW	7500	6000	5000	1000	800	750	500	400	300	250	200	150
1200/5A	20MW	15MW	12MW	10MW	7500	6000	1200	1000	800	600	500	400	300	250	200
1500/5A															

Power Factor Meter (Transducer Type) - PPK

POWER FACTOR METER ⁽¹⁾

Application	Type	Rating ⁽²⁾	Consumption VA		Accessory (Transducer)	
			Voltage	Current	80C	60C
Single phase	PPK-120NC-12 100NC-12 80C-12 60C-12	110V, 5A (1A)	1VA	1VA	PT-62M-12 ⁽⁵⁾	
		220V, 5A (1A)	1VA	1VA		
3 phase (balanced)	PPBK-120NC-33 100NC-33 80C-33 60C-33	110V, 5A (1A)	Each phase 1VA	Each phase 1VA	PBT-62M-33 ⁽⁵⁾	
		220V, 5A (1A)	Each phase 1VA	Each phase 1VA		
3 phase (unbalanced) ⁽⁴⁾	PPK-120NC-33 100NC-33 80C-33 60C-33	110V, 5A (1A)	Each phase 1VA	Each phase 1VA	PT-63M-33 ⁽⁵⁾	
		220V, 5A (1A)	Each phase 1VA	Each phase 1VA		
3 phase 4-wire (balanced)	PPBK-120NC-34 100NC-34 80C-34 60C-34	110V, 5A (1A)	Each phase 1VA	Each phase 1VA	PBT-62M-34 ⁽⁵⁾	
		220V, 5A (1A)	Each phase 1VA	Each phase 1VA		
3 phase 4-wire (unbalanced) ⁽³⁾⁽⁴⁾	PPK-120C-34 100C-34 80C-34 60C-34	110V, 5A (1A)	Each phase 1VA	Each phase 1VA	PT-64M-34 ⁽⁵⁾	
		220V, 5A (1A)	Each phase 1VA	Each phase 1VA		

Note:

- (1) Standard Scale is Lead0.5~1~Lag0.5. Scale for 3 phase 3-wire balance only is Lead0~1~Lag0.
(Effective measuring range: Lead0.3~1~Lag0.3 also can manufacture)
Please specify frequency (50Hz or 60Hz) for all type except 3 phase balanced circuit.
- (2) If above rating is exceeds, please use external CT, 5A(1A) or VT, 110V respectively.
Usable voltage range for 110V: 90~130V & 220V: 180~260V.
Please use in positive phase sequence.
- (3) All type PPK-120C, 100C, 80C, 60C-34 will be external with PT-64M-34.
- (4) 3 phase (unbalanced), 3 phase 4-wire (unbalanced) is voltage balanced.
- (5) Refer to next page for the connection diagram.

Dimensions for Attachment Transducer

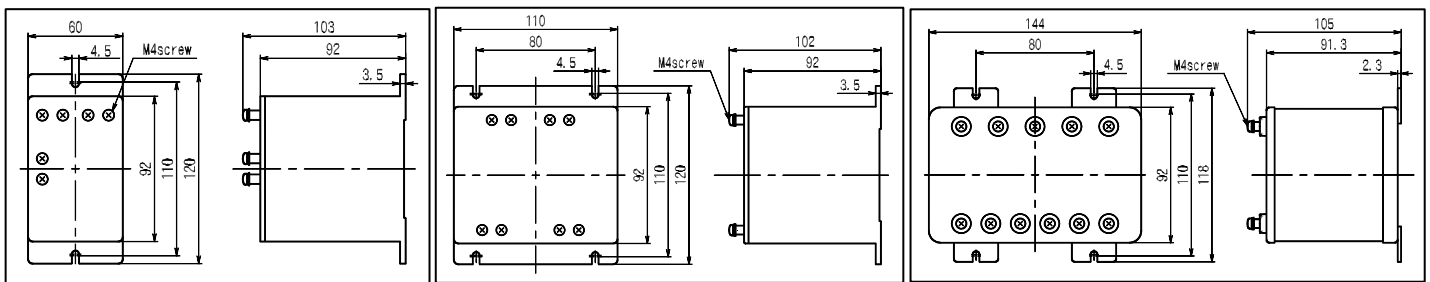

For Type: □T62M□-□

For Type: PT - 63M

For Type: PT - 64M

Type		A	B	C	D	E	F1	F2	G1	G2	K	weight (g)
PPK-120NC	PPBK-120NC	100	123	20	145.5	15	110Φ	112ΦHole	M5 Screw	7ΦHole	0	510
PPK-100NC	PPBK-100NC	80	100	16	135	15	85Φ	87ΦHole	M4 Screw	5.5ΦHole	0	500
PPK-80C	PPBK-80C	64	80	14.5	29.5	10	65Φ	67ΦHole	M3 Screw	4ΦHole	0	930
PPK-60C	PPBK-60C	48	60	14.5	29.5	10	52Φ	54ΦHole	M3 Screw	4ΦHole	6	890

Power Factor Meter (Transducer Type) - PPK

Connection Diagram & Dimensions (All-in-one Transducer Type)

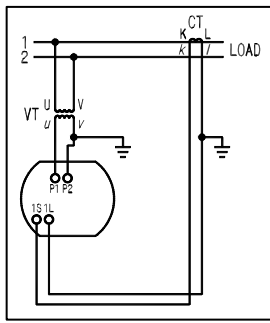

Single phase
Power factor meter

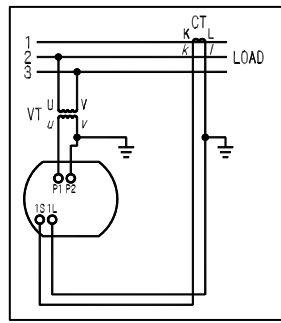

3 phase 3-wire
Power factor meter
(balanced)

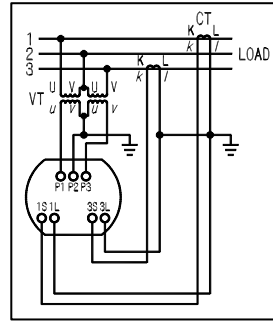

3 phase 3-wire
Power factor meter
(unbalanced)

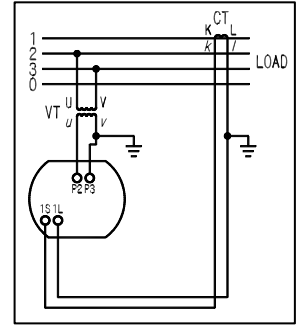

3 phase 4-wire
Power factor meter
(balanced)

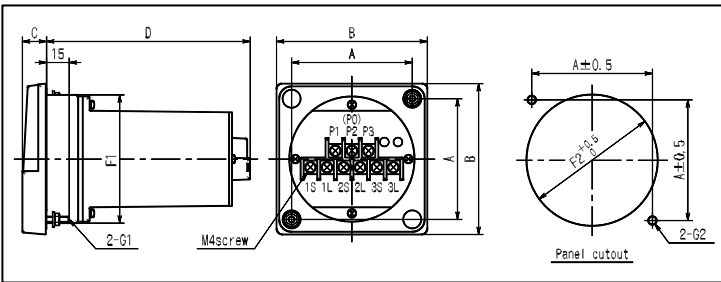

Connection Diagram & Dimensions (External with Transducer)

Note: Some error may be observed if phase sequence is wrong.

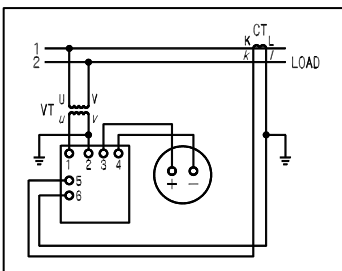

Single phase
Power factor meter
external with PT-62M-12

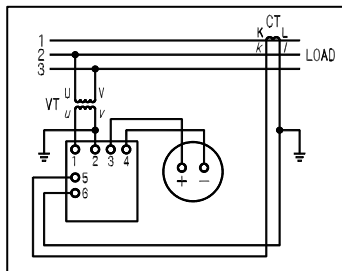

3 phase balanced
Power factor meter
external with PBT-62M-33

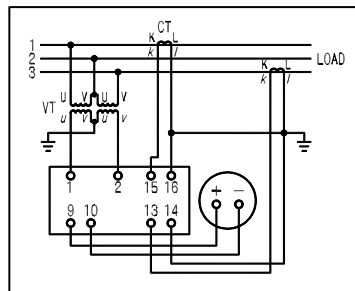

3 phase unbalanced
power factor meter
external with PT-63M-33

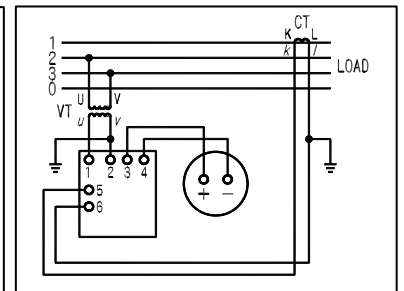

3 phase 4-wire
Power factor meter (balanced)
external with PBT-62M-34

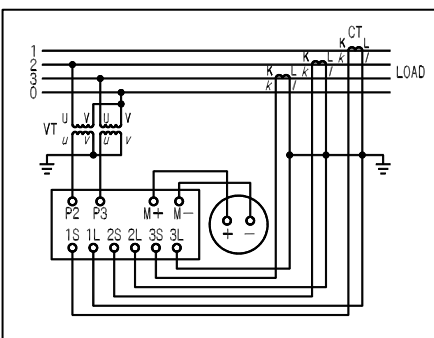

3 phase 4-wire
power factor meter (unbalanced)
external with PT-64M-34

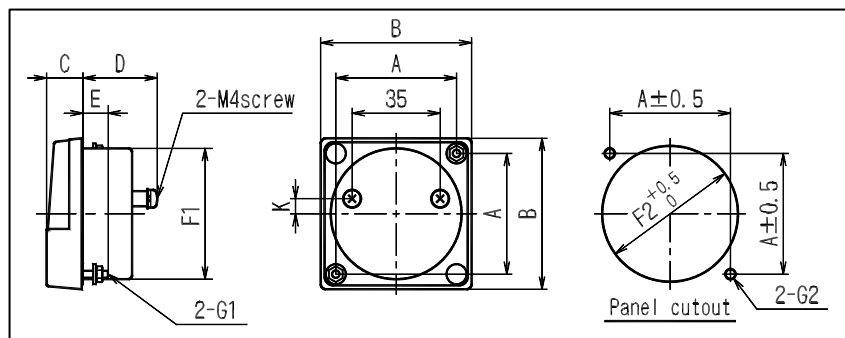

Frequency Meter (Transducer Type) - PAK

Rated Voltage	Measurement Range ⁽¹⁾	Consumption VA	Voltage Fluctuation Range
		PAK-120C, 100C, 80C, 60C	
110V	45~55Hz 55~65Hz 45~65Hz 350~450Hz	1.7VA	90~130V ⁽²⁾
220V	45~55Hz 55~65Hz 45~65Hz 350~450Hz	2.5VA	180~260V ⁽²⁾

Note:

⁽¹⁾ Special frequency measurement range also can manufacture (up until 1000Hz) Please specify.

⁽²⁾ Usable voltage range for 110V: 90~130V & 220V: 180~260V

Please contact with us for manufacture above rated voltage and voltage fluctuation range.

For SCR Waveform Meter

Meter SCR waveform input (Distortion waveform) also can manufacture.

Type name: PAK-□CH

Connection Diagram

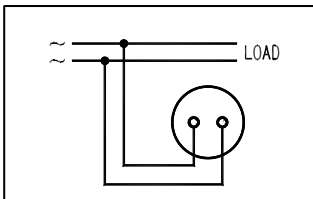

Frequency Meter

Dimensions

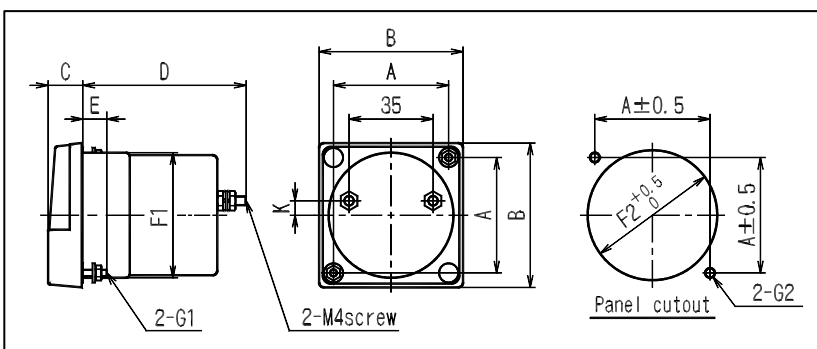

Type	A	B	C	D	E	F1	F2	G1	G2	K	weight (g)
PAK-120C	100	123	20	80	15	110Φ	112ΦHole	M5 Screw	7ΦHole	0	470
PAK-100C	80	100	16	69.5	15	85Φ	87ΦHole	M4 Screw	5.5ΦHole	0	300
PAK-80C	64	80	14.5	68	10	65Φ	67ΦHole	M3 Screw	4ΦHole	0	230
PAK-60C	48	60	14.5	68	10	52Φ	54ΦHole	M3 Screw	4ΦHole	6	150

Frequency Meter (Transducer Type) - PAK

METER EXTERNAL WITH LAMP

Product Name		PK-100C	PK-80C	PK-60C	Accessory
DC Ammeter , Voltmeter		PMK-100CL	PMK-80CL	PMK-60CL	—
DC Receiving Indicator		PXK-100CL	PXK-80CL	PXK-60CL	—
AC Receiving Indicator		PYK-100CL	PYK-80CL	PYK-60CL	—
AC Ammeter, Voltmeter		PSK-100CL	PSK-80CL	PSK-60CL	External DM-41 for PSK-60CL
AC Ammeter, Voltmeter		PCK-100CL	PCK-80CL	PCK-60CL	—
Watt Meter (unbalanced)		PWK-100CL-12,13,33,34	PWK-80CL-12,13,33,34	PWK-60L-12,13,33,34	External Transducer
Var Meter	Unbalanced	PWVK-100CL-12,33,34	PWVK-80CL-12,33,34	PWVK-60CL-12,33,34	External Transducer
	Balanced	PWVBK-100CL-33	PWVBK-80CL-33	PWVBK-60CL-33	External Transducer
Power	Unbalanced	PPK-100CL-12,33,34	PPK-80CL-12,33,34	PPK-60CL-33,34	External Transducer
Factor Meter	Balanced	PPBK-100CL-33,34	PPBK-80CL-33,34	PPBK-80CL-33,34	External Transducer
Frequency		PAK-100CL	PAK-80CL	PAK-60CL	External Transducer

Connection Diagram

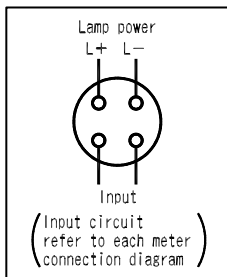

Dimensions

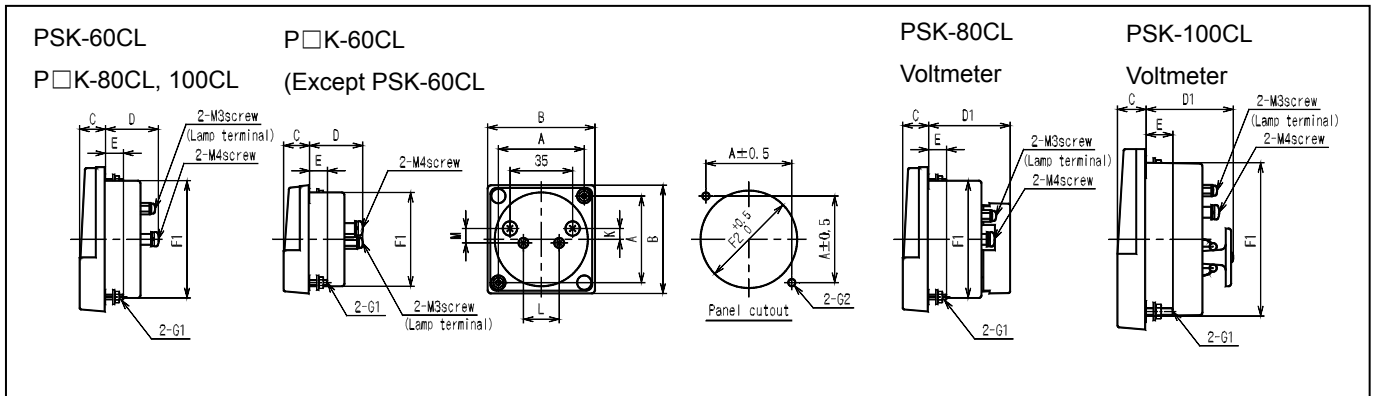

Type	A	B	C	D	D1	E	F1	F2	G1	G2	K	L	M	weight (g)
P□K-100CL	64	100	16	31	48	15	85Φ	87ΦHole	M4 screw	5.5ΦHole	0	35	17	180
P□K-80CL	48	80	14.5	29.5	45.5	10	65Φ	67ΦHole	M3 screw	4ΦHole	0	35	17	125
P□K-60CL	48	60	14.5	30.5	-	10	52Φ	54ΦHole	M3 screw	4ΦHole	6	20	8	90

Please refer to below for PSK

Type	A	B	C	D	D1	E	F1	F2	G1	G2	K	L	M	weight (g)
PSK-100CL	64	100	16	41.5	48	15	85Φ	87ΦHole	M4 screw	5.5ΦHole	15	25	12	260
PSK-80CL	48	80	14.5	39.5	45.5	10	65Φ	67ΦHole	M3 screw	4ΦHole	0	38	13	165
PSK-60CL	48	60	14.5	40.5	-	10	52Φ	54ΦHole	M3 screw	4ΦHole	6	13	6	130

Instrument Accessory

Current Transformers (CT) & Voltage Transformers (VT)



It is possible to combine the instrument in 5A or 1A after converted by current transformer when measuring a large current.

Primary Winding Type, Circle Window Type & Square Window Type. There are 3 types can use depending on the magnitude of the current.

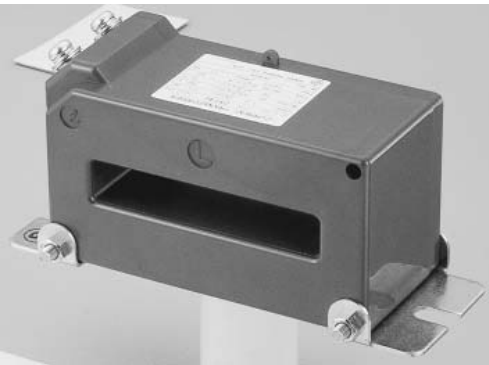

It is possible to combine the instrument in 110V after converted by voltage transformer when measuring a large voltage.

FEATURES

- ▶ High quality & high performance current transformer.
This product is compliance with:
JIS C-1731-1 standard Instrument current transformer &
JED-1201 standard Instrument voltage transformer.
Class: 1.0
Tolerance: $\pm 1.0\%$
- ▶ Depending to the intended use, we have few selections for current transformer & voltage transformer like mold type or dry open type can be choice.



Specification List for Current Transformers (CT) & Voltage Transformers (VT)

Instrument Transformers

- ◆ JIS C 1731-1 standard for Current Transformer & JEC-1201 standard for Voltage Transformer
- ◆ Instrument transformer have few selections depending to the intended use like mold type or dry open type etc.
- ◆ Low voltage transformer wiring work is easy & compact.
- ◆ Please use epoxy resin mould type for high insulation spacificaton.

List of Current Transformers

Max. circuit voltage (V)	Construction	Insulated system	Type Name	Primary current (A)	Secondary current (A)	Rated burden (VA)	Class	Frequency (Hz)	Over current (Times)	weight (kg)
Below 1,150	Circle Window	ABS resin	CPI-1TR	5~300	* 5	10	1.0	50/60	40	0.5
		Epoxy resin Mould ABS coated	CR2-5	10~750	5	5	1.0	50/60	40	0.8
			CR2-15	10~750	5	15	1.0	50/60	40	0.7
			CR2-40	20~750	5	40	1.0	50/60	40	0.9
	Square Window	Epoxy resin Mould ABS coated	CS1-15	200~750	5	15	1.0	50/60	40	1.2
			CS1-40	200~2,000	5	40	1.0	50/60	40	1.1
	Primary Winding	ABS resin	CPX-15	5~30	* 5	15	1.0	50/60	40	0.75

- ◆ Product with mark * can be manufacture by secondary current 1A.

List of Voltage Transformers

Max. circuit voltage (V)	Construction	Insulated system	Type Name	Primary current (A)	Secondary current (A)	Rated burden (VA)	Class	Frequency (Hz)	AC Withstand voltage	weight (kg)
Below 230	Winding Type	Dry opening type	PDI-1	220	110	15	1.0	50/60	2kV, 1 min	2.2
Below 460						50				3.6
						100				6.5
Below 460	With a fuse	Epoxy resin mould	RP-111N	220	110	50	1.0	50/60	2kV, 1 min	5.0
				440					3kV, 1 min	
			RP-112N	220	110	100	1.0	50/60	2kV, 1 min	6.0
				440					3kV, 1 min	
			RP-113N	220	110	200	1.0	50/60	2kV, 1 min	8.5
				440					3kV, 1min	

Current Transformers (CT)

Circle Window Type (Below 1,150V)

Insulated System	Type Name	Primary current (A)																						Secondary current (A)	Rated Burden (VA)
		/	5	10	15	20	25	30	40	50	60	75	80	100	120	150	200	250	300	400	500	600	750		
ABS resin	CPI-1TR	*T	24	15	10	8	6	5	4	3	3	2	2	2	1	1	1	1	1	-	-	-	-	5	10
Epoxy resin ABS coated	CR2-5	*T	-	10	8	5	4	4	3	2	2	2	-	1	1	1	1	1	1	1	1	1	1	5	5
	CR2-15	*T	-	15	10	10	6	5	5	3	4	2	3	2	2	1	1	1	1	1	1	1	1	5	15
	CR2-40	*T	-	-	-	10	8	7	5	4	4	4	3	2	2	2	1	1	1	1	1	1	1	5	40

* T = Number of primary conductor penetration.

CPI-1TR 10VA

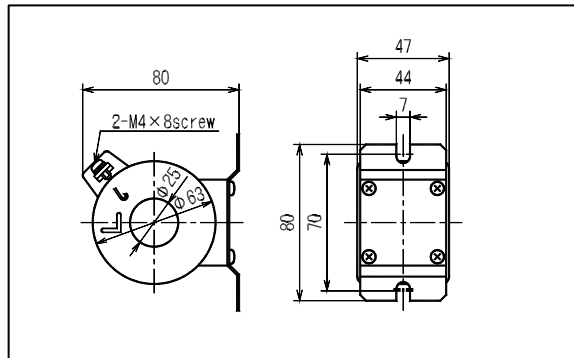

CR2-5

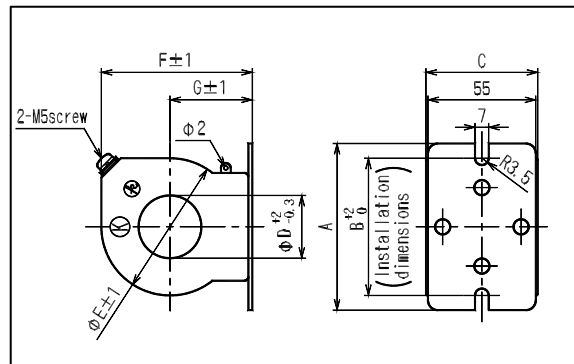

Primary Current (A)	A	B	C	ΦD	ΦE	F	G
10~200	85	70	57	23	61	70	37
240~400	85	70	55	32	70	77	42
500~750	100	85	57	50	86	93	50

Current Transformers (CT)

Circle Window Type (Below 1,150V)

CR2 – 15

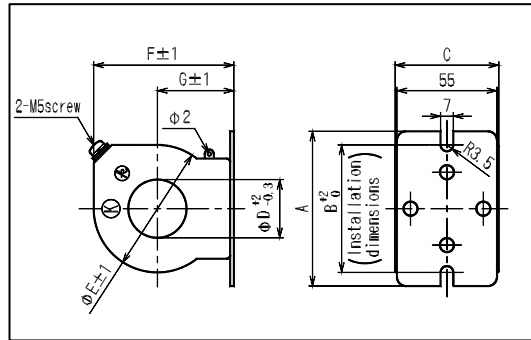

Primary Current (A)							A	B	C	ΦD	ΦE	F	G
10	15	25	30	50	75	150	100	85	57	25	76	83	45
60	80	120	240~400				85	70	55	32	70	77	42
20	40	100	200				100	85	55	32	70	77	42
500~750							100	85	57	50	86	93	50

CP2 – 40

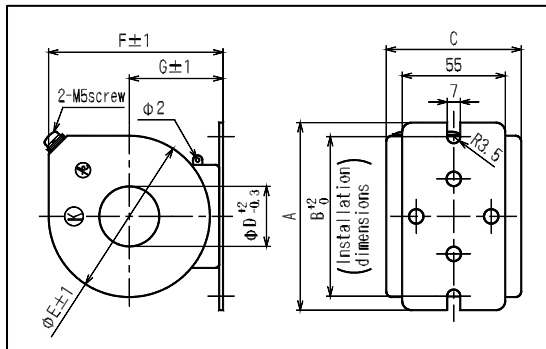

Primary Current (A)	A	B	C	ΦD	ΦE	F	G
20~400	100	85	72	32	86	93	50
500~750	100	85	57	50	86	93	50

Current Transformers (CT)

Square Window Type (Below 1,150V)

Insulated System	Type Name	Primary Current (A)	Secondary Current (A)	Rated Burden (VA)	A	B	C	D	E	F	G	H	J	W	t
Epoxy resin Mould ABS coated	CS1-15	200, 300, 400, 500	5	15	137	118	101	75	73	39	50	53	69	55	14
		600, 750			150	131	114	64	62	33	50	53	69	80	14
	CS1-40	200	5	40	163	144	130	107	104	55	65	68	84	55	14
		300,400,500			137	118	101	75	73	39	50	53	69	55	14
		600, 750			150	131	114	64	62	33	50	53	69	80	14
		1,000, 1,200, 1,500, 2,000			169	150	133	82	80	42	50	53	69	105	28

◆ Fitting metal for bus bar also available (Option onerous)

CS1-15, CS1-40

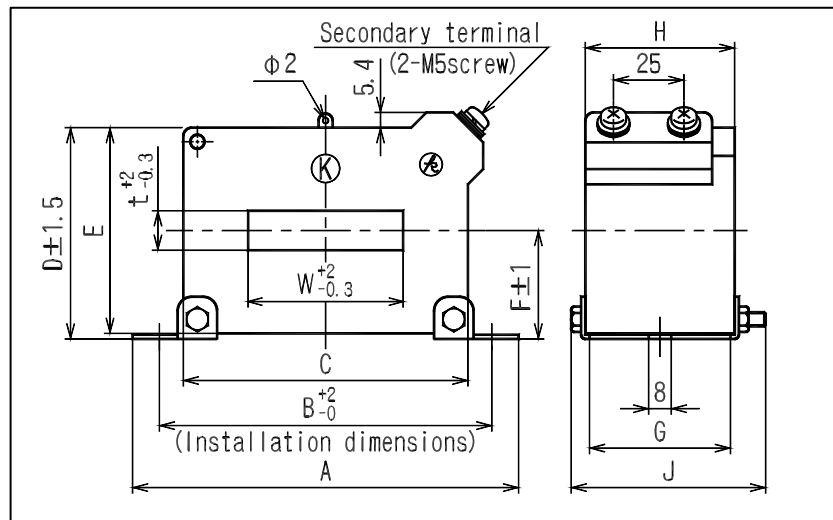
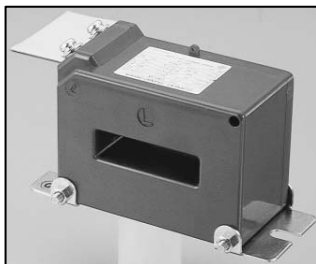
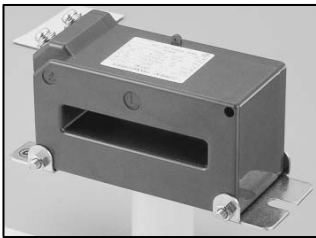

Primary Winding Type

Insulated System	Type Name	Primary Current (A)	Secondary Current (A)	Rated Burden (VA)
ABS resin	CPX-15	5, 10, 15, 20, 30	5	15

CPX - 15

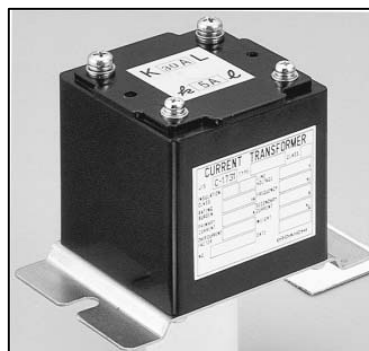
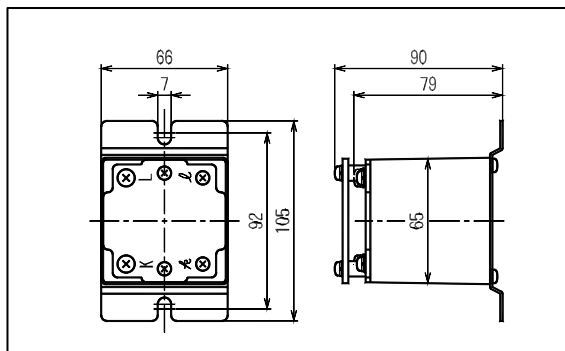

Voltage Transformers (VT)

For low voltage Instrument use below 460V & 230V

1) Dry Open Type

Type Name	Max. Circuit Voltage (V)	Primary Voltage (V)	Secondary Voltage (V)	Rated Burden (VA)	Dimension (mm)					
					A	B	C	A'	B'	D' (Attachment)
PDI - 1	230	220	110	15	100	90	110	70	75	6 × 15 cut
				50	120	100	125	74	85	7 × 15 cut
				100	135	130	140	84	105	7 × 15 cut
	460	440	110	15	100	90	110	70	75	6 × 15 cut
				50	120	100	125	74	85	7 × 15 cut
				100	135	130	140	84	105	7 × 15 cut

For below 460V

2) Epoxy Resin Mould

Type Name	Max. Circuit Voltage (V)	Primary Voltage (V)	Secondary Voltage (V)	Rated Burden (VA)	Dimension (mm)				
					A	B	C	F	H
RP-111N	460	220, 440	110	50	100	90	70	116	135
RP-112N				100	114	90	70	134	160
RP-113N				200	114	100	80	154	162

RP-111N, RP-112N, RP-113N

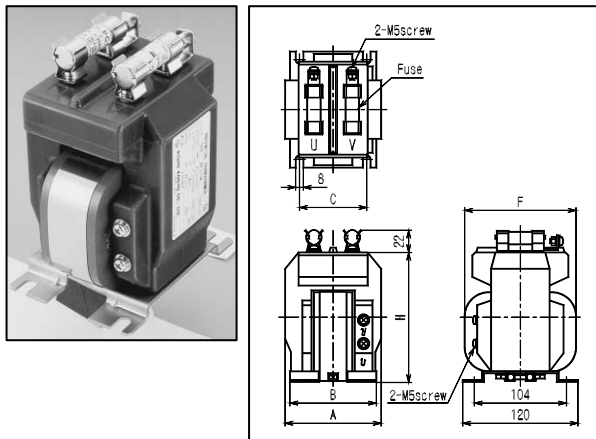

PDI-1

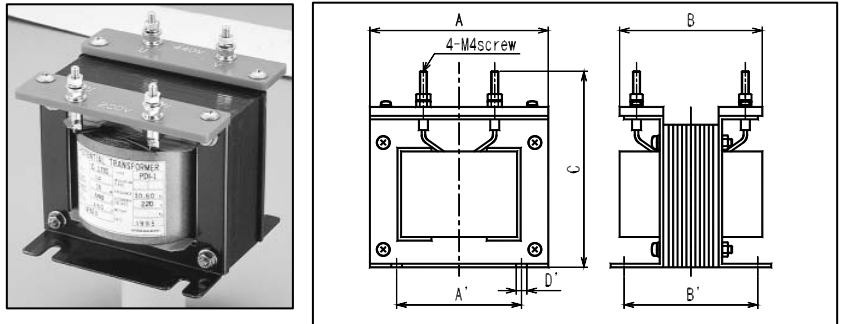

◆ Item To Specify When make Purchase

- 1) Type name
- 2) Primary current (voltage) / Secondary current (voltage)
- 3) Rated burden (VA)

Instrument Accessory

Direct Current Shunt & Resistor Series

SHUNT



Shunt is possible to combine with mill voltmeter for measuring a large current.

There are 2 types wire connection with insulating stand & bus bar connection can use depending on the magnitude of the current.

FEATURES

▶ High reliability & high performance shunt.

This product is compliance with:

JIS C-1721-1976 standard.

Class: 1.0

Tolerance: $\pm 1.0\%$

▶ Continuous excitation current have set at 80% or less on the rated value.

▶ We have 2sets voltage terminal DSW type.

▶ Also have 3sets output terminal DST type for consideration of the heat dissipation and avoid rise in the temperature.

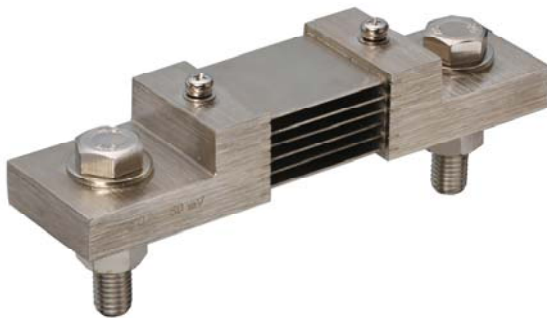

RESISTOR SERIES

External with resistor series is possible to combine with milliampere meter for measuring a large voltage.

FEATURES

▶ High reliability & high performance resistor series.

▶ There are 7 types from DM-1 (750V) until DM-25 (25kV) can use depending on the magnitude of the voltage.

▶ DM-2~25 will built-in the measures against open resistor.



DC SHUNTS

For DC Shunts

- ◆ Shunts type DS, DSW and DST is compliance with standard JIS (JIS C-1721-1976).
Continuous excitation current is 80% or less of the range value.
Please consultation with us when specification overload capacity or other is different.
- ◆ Standard for shunts terminal voltage is 60mV and 100mV, Please refer to diagram at below and specify it.
- ◆ Power consumption of shunt is (Current) X (Millivolt) which becomes larger in proportionality of the rated current.
- ◆ Please attach especially a large current shunt in consideration of radiation to make the minimize temperature rise of a resistor part.
- ◆ Please clamping enough the connection of the electric wire, so that contact resistance becomes small.
- ◆ Pay attention not to make a contact between current terminal and voltage terminal electrically to prevent error.

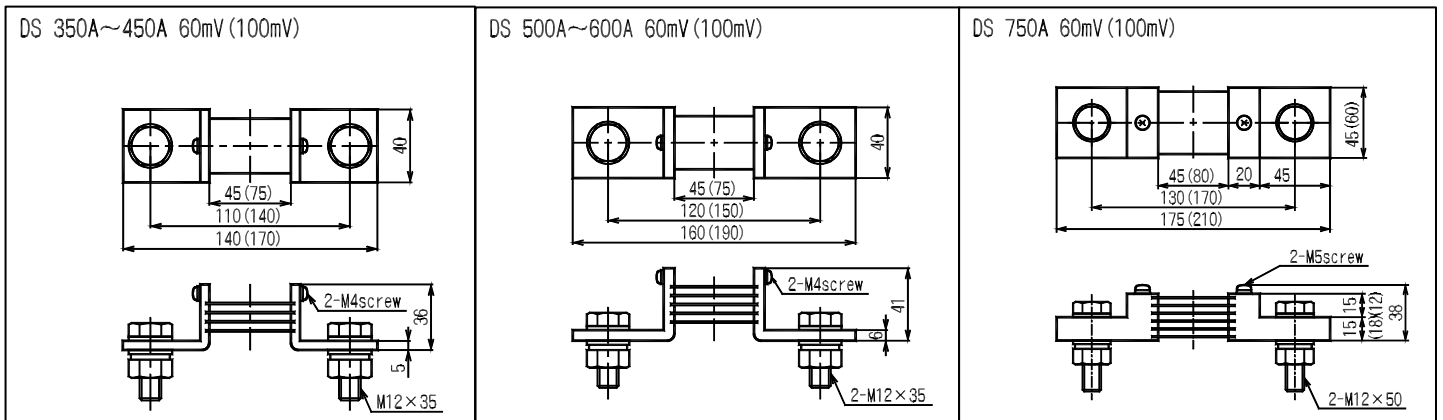
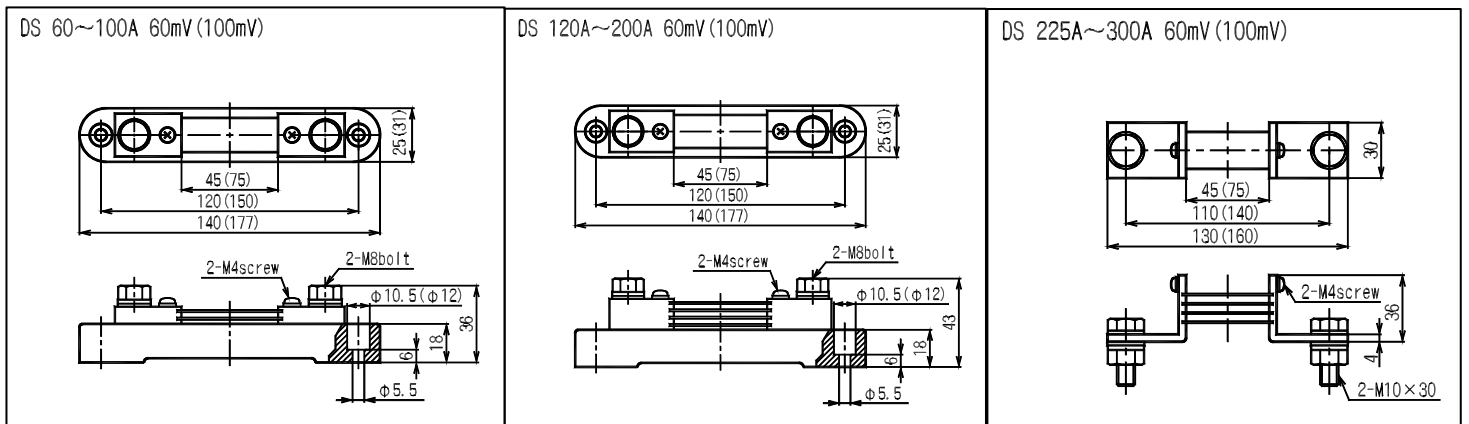
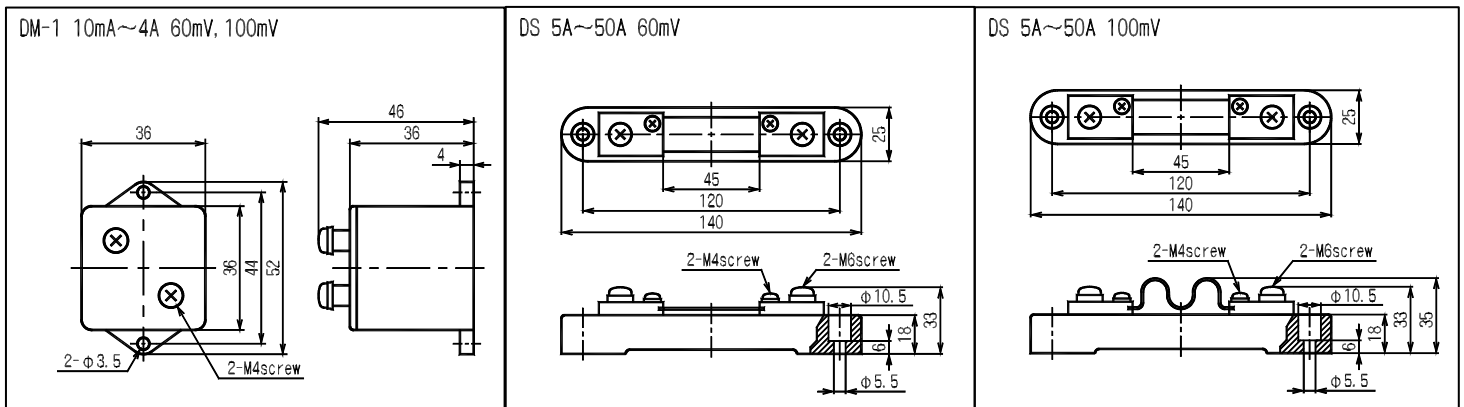

DS SHUNTS

DS 1000A 60mV

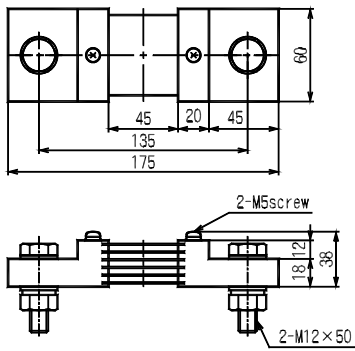

DS 1500A 60mV (1000A 100mV)

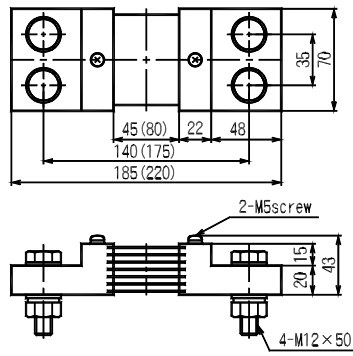

DS 2000A 60mV (1500A 100mV)

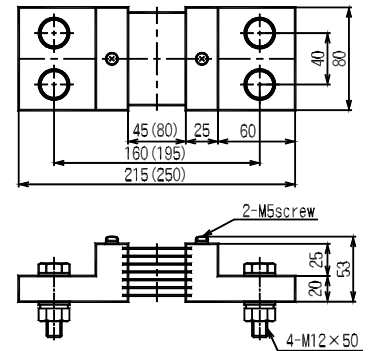

DS 2500A 60mV (2000A 100mV)

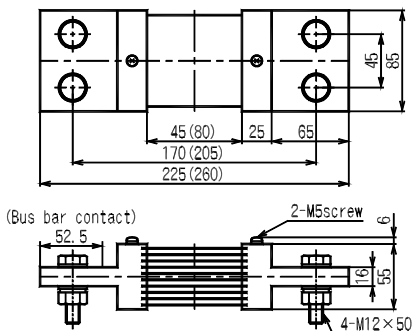

DS 2500A 100mV

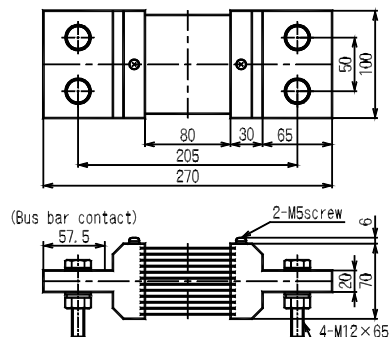

DS 3000A 60mV (100mV)

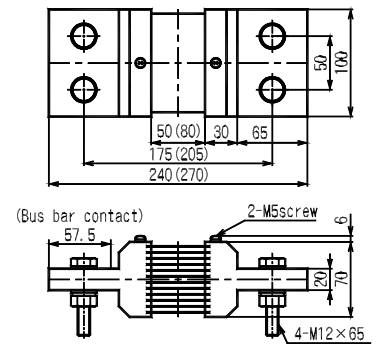

DS 4000A 60mV (100mV)

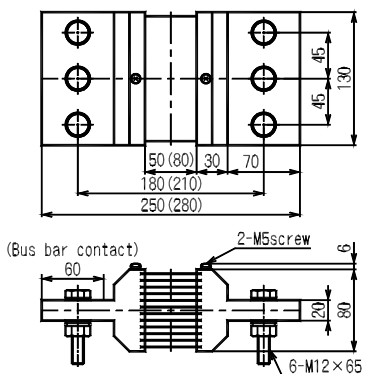

DS 5000A 60mV (100mV)

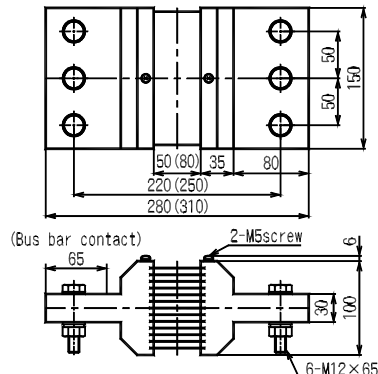

- ◆ Please consultation with us when 5000A is exceeding.
- ◆ Please inform us if the load resistance value is less than 900A (by our indication meter type name)
- ◆ Please specify the item as below when make order
 - 1) Type Name
 - 2) Input (A)/ output (mV)
 - 3) Option (with or without shunt stand etc.)

DS SHUNTS

For DST Type Shunt

- ◆ Standard JIS C 1721-1976.
- ◆ Standard shunt terminal voltage is 60mV and 100mV, other voltage also can manufacture please request.
- ◆ There are 3 sets output terminal.
- ◆ Manufactured this product in consideration of the heat dissipation avoid rise in the temperature.

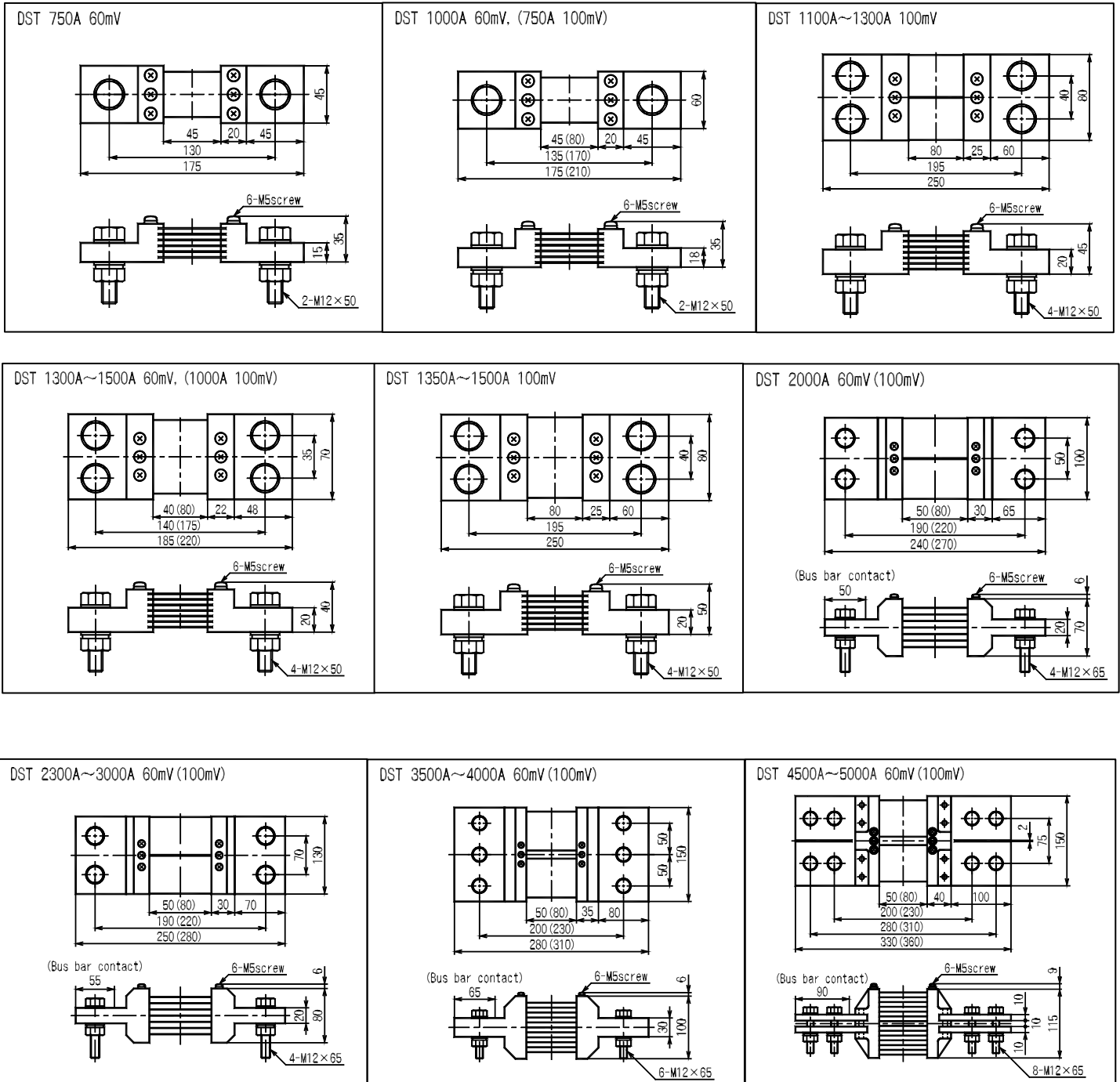

- ◆ Please consultation with us when 5000A is exceeded.

RESISTOR SERIES

External with Resistor Series

DM – 1 (Below 1000V)

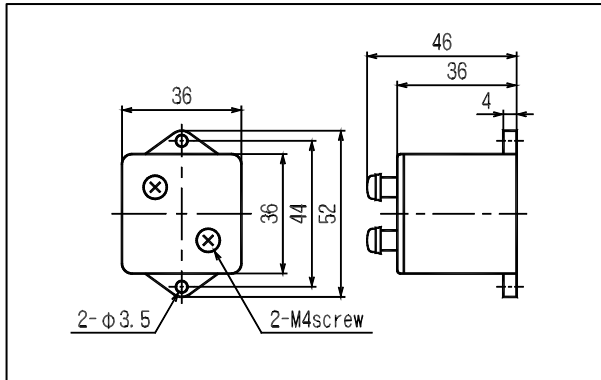

DM – 1T (Rectifier built in)

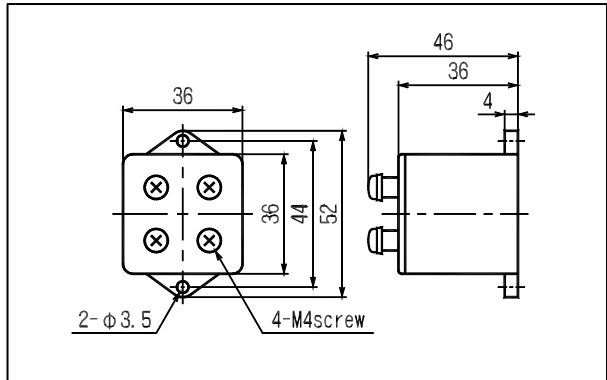

DM – 2 (Below 2500V)

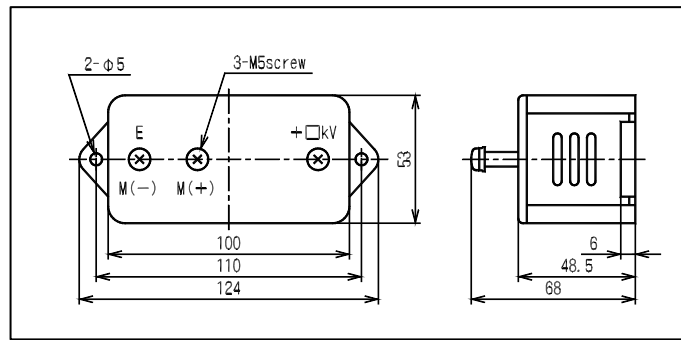

DM – 5, 10, 15, 20, 25 (5~25kV)

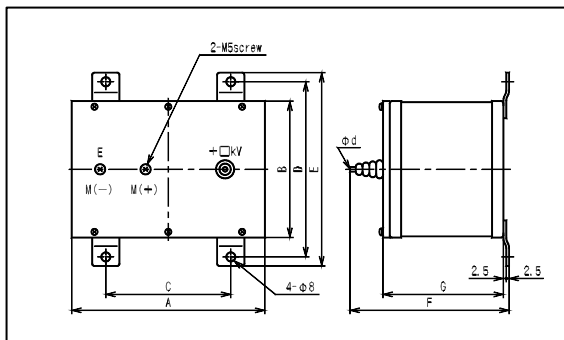

Type Name	Rated	A	B	C	D	E	F	G	d
DM – 5	5000V	170	120	110	154	170	140	106	4
DM – 10	10kV	220	160	140	194	210	140	106	4
DM – 15	15kV	290	210	200	248	264	190	146	5
DM – 20	20kV	390	260	300	294	310	220	176	5
DM – 25	25kV	500	330	400	356	372	280	236	5

OPTIONS

1. TERMINAL COVER FOR TYPE WIDE ANGLE L SERIES

Terminal Cover for Type ML- 6 and ML- 5

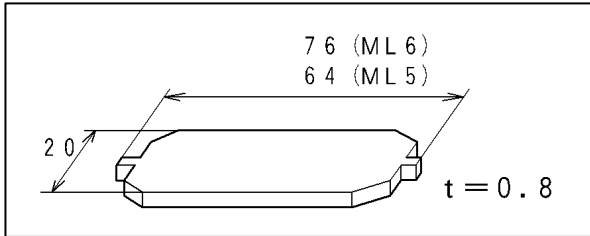

Set into terminal block

Type Name	Units Required	
	ML-6	ML-5
ML-110C, YL-110C, XL-110C, CL-110C, AL-110C, PL-110NC-12, PBL-110NC-33, WL-110NC-12, WVL-110NC-12,	-	1
WL-110NC-33, 34 WVL-110NC-33, 34	1	1

Terminal Cover for Type ML- 3

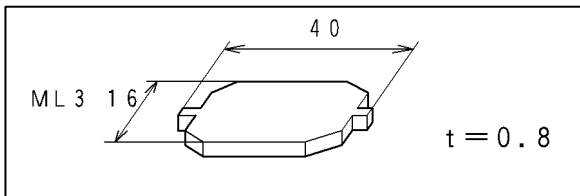

Set into terminal block

Type Name	Units Required		
	ML-6	ML-5	ML-3
ML-80C, YL-80C, XL-80C, CL-80C, AL-80C, PL-80C-12	-	-	1
WL-80C-12, 33, 34 Attach with transducer	WT-53MC-12	1	-
	WT-53MC-33	1	1
	WT-53MC-34 ⁽¹⁾	1	1
WVL-80C-12, 33, 34 Attach with transducer		-	1
	WVT-53MC-12	-	-
	WVT-53MC-33	1	1
	WVT-53MC-34 ⁽²⁾	1	1
PL-80C-33, 34 Attach with transducer		-	1
	PT-53MC-33, 34	1	1

⁽¹⁾ For WT-53MC-34, use two OA-BCP3 made by OHM.
⁽²⁾ For WVT-53MC-34, use two OA-BCP3 made by OHM.

2. TERMINAL COVER FOR TYPE WIDE ANGLE L SERIES

Terminal Cover For Type SL

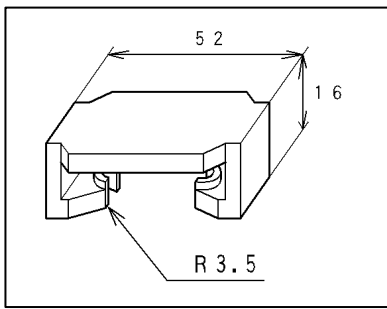

Set into terminal block

Terminal Cover For Narrow Angle

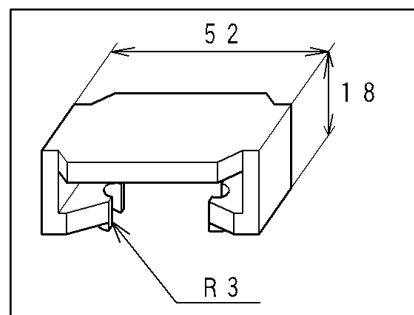

Type Name	Units Required	
	SL terminal cover	Narrow-angle terminal cover
SL-110C	1	-
SL-80C	1	-
L-65C	-	1

3. TERMINAL COVER FOR TYPE WIDE ANGLE L SERIES

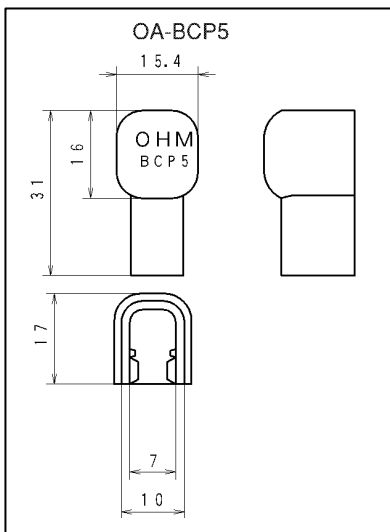

Set into terminal fitting

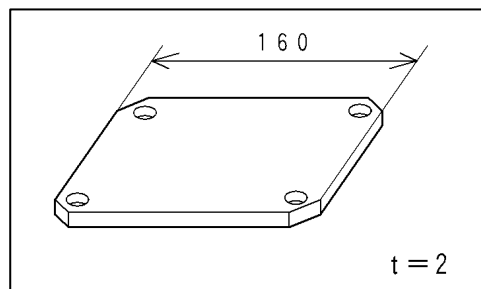

Multiplier covers for single phase
Synchroscope meter (Cover: DMD-50)
Lock screw on pillar.

Type Name	Unit Required	
	OA-BCP5	Cover DMD-50
DL-110C-12	6	1
DL-110NC-33	5	-

* Please specify cover DMD-50 when ordering. The meter shall be shipped with the cover fixed.

4. TERMINAL COVER FOR TYPE NARROW ANGLE METER COMMON

Narrow Angle Terminal Cover

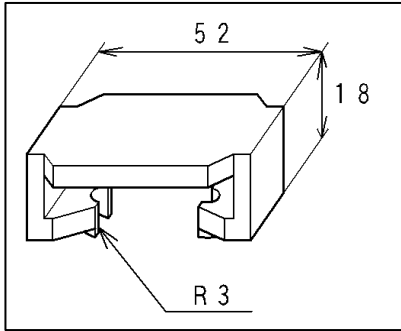

Set into terminal fitting

Hz Terminal Cover

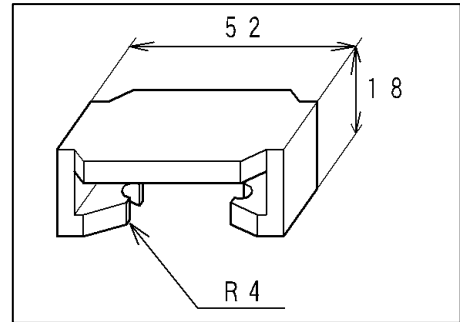

Type Name	Measurement Element	Mark	Narrow Angle Terminal Cover	Hz Terminal Cover
			Units Required	
P K-120C/ 100C/ 80C/ 60C (Except 120NC1, 100NC) L K-12C/ 10C/ 8C (Except 12C, 10C, 8C) P D-96 (Except P D-96N) F K-7/ 5 FAK-7C/ 5C PAD-96	DC Current / Voltage	M	2pcs terminal cover is necessarily for P D-96 Series 2 Pointers type	-
	DC Receiving Indicator Meter	X		
	AC Receiving Indicator Meter	Y		
	AC Current / Voltage	S		
	AC Current / Voltage	C		
	AC Watthour Meter	W		
	AC Var Meter (balanced)	WVB		
	AC Var Meter (unbalanced)	WV		
	Power Factor (balanced)	PB		
	Power Factor (unbalanced)	P		
	Heat Electric Temperature	H		
	Heat Electric Temperature	HT		
	Revolutions (DC)	Z		
	Revolutions (AC)	V		
PAK-120C/ 100C/ 80C/ 60C LAK-12C/ 10C/ 8C/ 6C	Frequency	A	-	1

5. TERMINAL COVER FOR TYPE NARROW ANGLE PK/ LK INTERGRATED

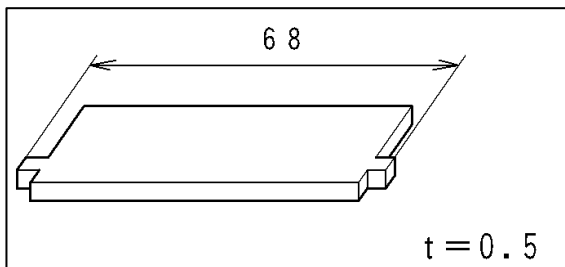

Set into terminal block

Meter Type	Units Required
	Kw Terminal Cover
P K- NC-	1
L K- NC-	

6. TERMINAL COVER FOR TYPE F SERIES

Terminal Cover For Type MF

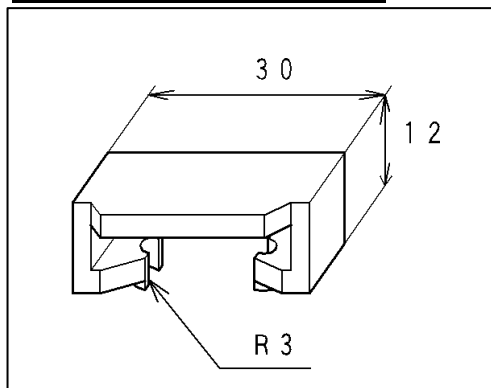

Use specify terminal cover or
OA-BCP3 for attachment transducer

Type Name	Measurement Element	Mark	Units Required	
			1 Pointers	2 Pointers
F - 17 F - 15 F - 10	DC Current/ Voltage	M	1	2
	DC Receiving Indicator Meter	X	1	2
	AC Receiving Indicator Meter	Y		
	AC Current/ Voltage	C		
	AC Watthour Meter	W		
	AC Var Meter (balanced)	WVB		
	AC Var Meter (unbalanced)	WV		
	Power Factor (balanced)	PB		
	Power Factor (unbalanced)	P		
	Frequency	A		
	Heat Electric Temperature	H		
	Heat Electric Temperature	HT		
	Revolutions (DC)	Z		
Revolutions (AC)	V			

7. TERMINAL COVER FOR TYPE PWD – 96

Terminal Cover For Tye PWD – 96

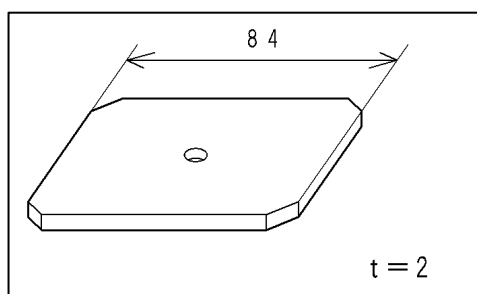

Narrow Angle Terminal Cover

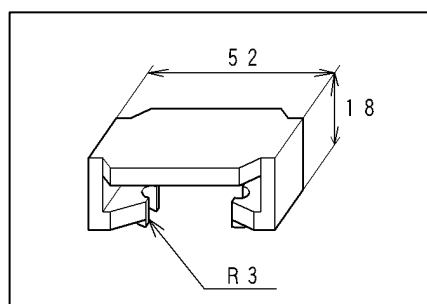

Please use nut to lock the meter stud.

Type Name	Measurement Element	Mark	Unit Required	
			Terminal Cover PWD-96	Narrow Angle Terminal Cover
P D-96N-	Power	W	1	1 Pointer
	Reactive Power	WV		2 Pointers
	Power Factor (balanced)	P		-
	Power Factor (unbalanced)	PB		-
P D-96- -	Power	W	-	1
	Reactive Power	WV		1
	Power Factor (balanced)	P		1
	Power Factor (unbalanced)	PB		1

Use specify terminal cover or OA-BCP3 for attachment transducer

8. TERMINAL COVER FOR TYPE EL SE

Terminal Cover For Type EL

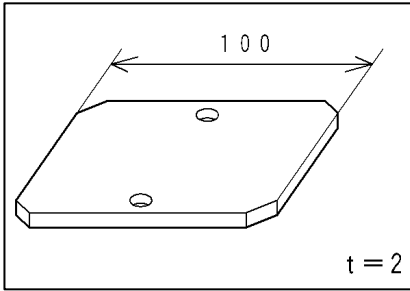

Lock screw on pillar.

Type Name	Measurement Element	Mark	Terminal Cover Type EL
			Units Required
Wide Angle Meter Relay EL-110C	DC Current/ Voltage	M	1
	DC Receiving Indicator Meter	X	
EP Series Normal Angle Meter Relay (All-in-one Type Relay Box) EP-100NC/ 120NC	AC Receiving Indicator Meter	Y	
	AC Current/ Voltage	S	
EK Series Normal Angle Meter Relay (All-in-one Type Relay Box) EK-12NC	AC Current/ Voltage	C	
	AC Watthour Meter	W	
	AC Var Meter (balanced)	WVB	
	AC Var Meter (unbalanced)	WV	
	Power Factor (balanced)	PB	
	Power Factor (unbalanced)	P	
	Frequency	A	
	Heat Electric Temperature	H	
Heat Electric Temperature	HT		
Revolutions (DC)	Z		
Revolutions (AC)	V		

9. TERMINAL COVER FOR TYPE DM – 61

Terminal Cover For Type DM – 61

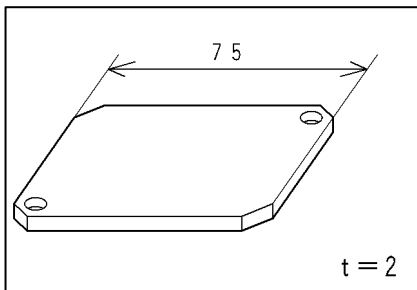

Lock screw on pillar.

Attached Relay Box	Terminal Cover Type DM – 61
Type Name	Units Required
DM – 61	1

* Please use EP/ EK series normal angle attached relay box for DM-61 terminal cover.

10. TERMINAL COVER FOR TYPE EF SERIES

Terminal Cover For EF Serie

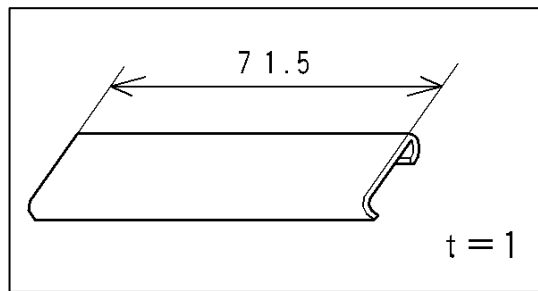
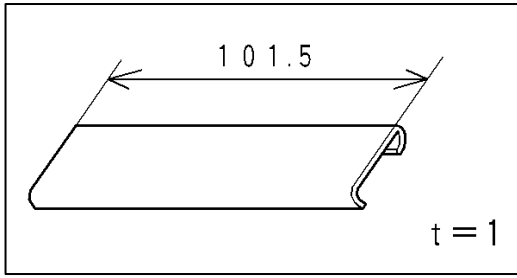

Type Name	Measurement Element	Mark	Terminal Cover For EF Series
			Units Required
EF - 17	DC Current/ Voltage	M	1
EF - 15	DC Receiving Indicator Meter	X	
	AC Receiving Indicator Meter	Y	
	AC Current/ Voltage	S	
	AC Current/ Voltage	C	
	AC Watthour Meter	W	
	AC Var Meter (balanced)	WVB	
	AC Var Meter (unbalanced)	WV	
	Power Factor (balanced)	PB	
	Power Factor (unbalanced)	P	
	Frequency	A	
	Heat Electric Temperature	H	
	Heat Electric Temperature	HT	
	Revolutions (DC)	Z	
	Revolutions (AC)	V	

RTF - 15	-	1
RTF - 10	-	1

11. TERMINAL COVER FOR HIGHEST (LOWEST) INDICATOR METER

Terminal Cover MRL

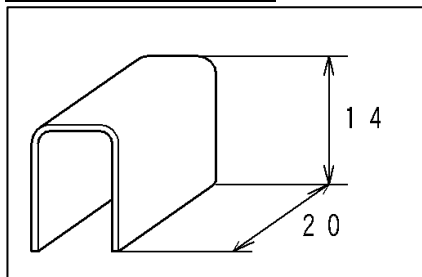

Set into terminal fitting

Type Name	Measurement Element	Mark	Terminal cover for MRL
Highest (Lowest) Indicator Meter	DC Current/ Voltage	M	2
	DC Receiving Indicator Meter	X	
	AC Receiving Indicator Meter	Y	
RL-110CH, 110CL, 110CHL	AC Current/ Voltage	S	2 addition for electromagnetism return 2 addition for Aux. Power Supply
	AC Current/ Voltage	C	
	AC Watthour Meter	W	
RL-80CH, 80CL, 80CHL	AC Var Meter (balanced)	WVB	
	AC Var Meter (unbalanced)	WV	
	Power Factor (balanced)	PB	
	Power Factor (unbalanced)	P	
	Frequency (Except PAK, LAK)	A	
	Heat Electric Temperature	H	
	Heat Electric Temperature	HT	
	Revolutions (DC)	Z	
	Revolutions (AC)	V	

* Please Use specify terminal cover or OA-BCP3 for attachment transducer

12. TERMINAL COVER FOR HIGHEST (LOWEST) INDICATOR (ALARM CONTACT)

Terminal Cover ERL

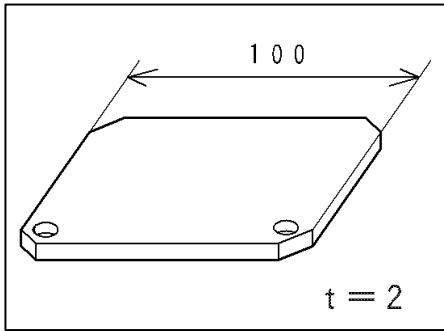

Lock by screw

Type Name	Measurement Element	Mark	Terminal cover for ERL
Highest (Lowest) Indicator Meter (Alarm Contact) ERL-110C-H, 110C-L, 110C-HL	DC Current/ Voltage	M	1
	DC Receiving Indicator Meter	X	
	AC Receiving Indicator Meter	Y	
	AC Current/ Voltage	S	
	AC Current/ Voltage	C	
	AC Watthour Meter	W	
	AC Var Meter (balanced)	WVB	
	AC Var Meter (unbalanced)	WV	
	Power Factor (balanced)	PB	
	Power Factor (unbalanced)	P	
	Frequency (Except PAK, LAK)	A	
	Heat Electric Temperature	H	
	Heat Electric Temperature	HT	
	Revolutions (DC)	Z	
Revolutions (AC)	V		

* Please Use specify terminal cover or OA-BCP3 for attachment transducer

13. TERMINAL COVER FOR MAX. DEMAND AMMETER

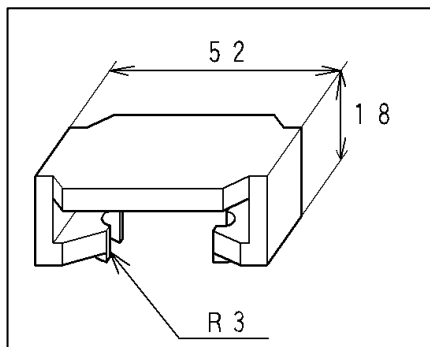

Set into terminal fitting

Type Name	Terminal Cover For Narrow Angle
	Units Required
Max. Demand Ammeter BRL - 110CH	1
Max. Demand Ammeter (With warning contact)	2

14. TERMINAL COVER FOR AUXILIARY CT

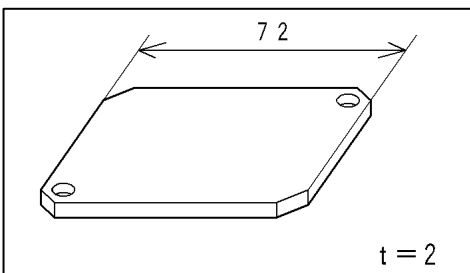

Accessory CT Type	Units Required
	Terminal Cover For MR-CTN
MR - CTN	1

Please use accessory CT cover for Accessory CT, MR-CTN.

15. ATTACHMENT TRANSDUCER TERMINAL COVER

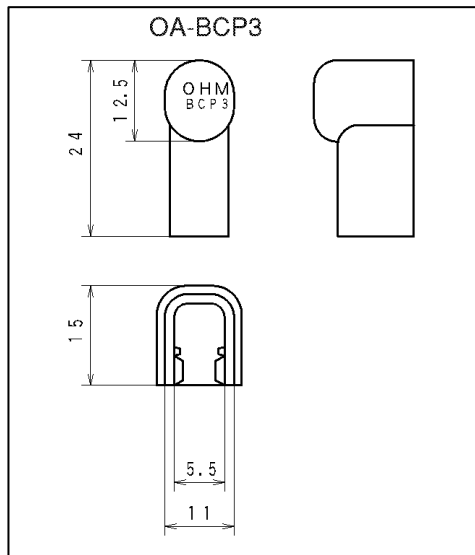

Set into terminal fitting

Terminal Cover for T-83M

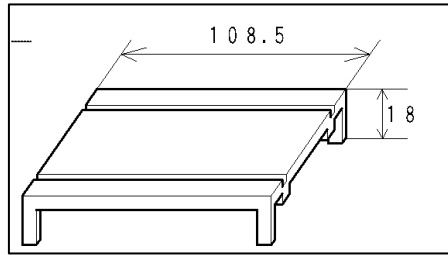

Attachment Transducer	Units required	
	OA-BCP3	T-83 terminal cover
A(V)T-62M	4	-
W(WV, P, PB)T-62M	6	-
PT-63M	8	-
DM-63(H, L)	10	-
DM-63(HL, HH, LL)	16	-
W(WV, P, PB)T-64M-12	6	-
W(WV, P, PB)T-64M-34	11	-
PT-64M-34	10	-
-T-83M-	-	1

* Please Use specify terminal cover or OA-BCP3 for attachment transducer

16. SERIES RESISTOR TERMINAL COVER

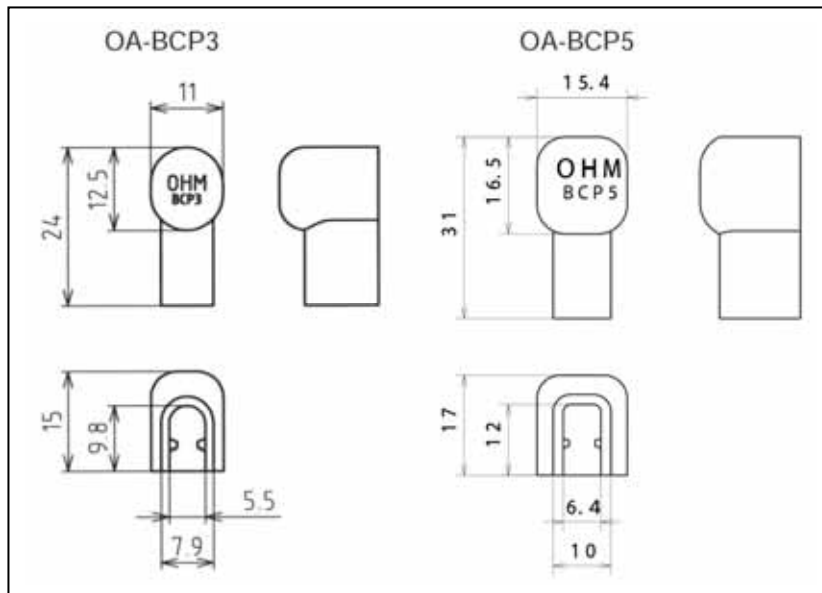

Set into terminal fitting

Type	Units Required	
	OA-BCP3	OA-BCP5
DM - 1	2	-
DM - 2	-	3
DM - 1T	4	-
DM - 41	-	2

EX. SCALE

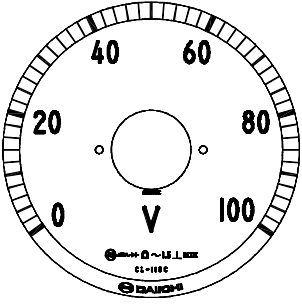
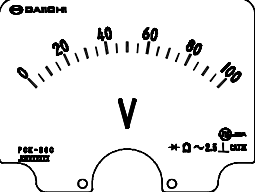
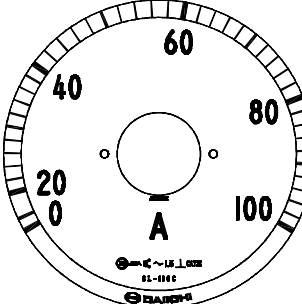
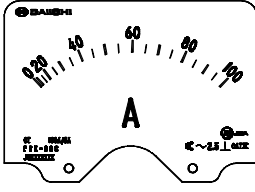
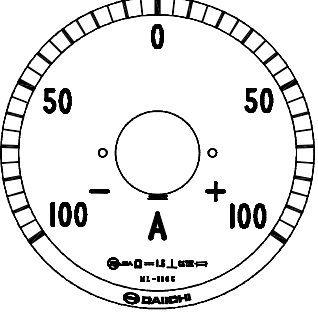
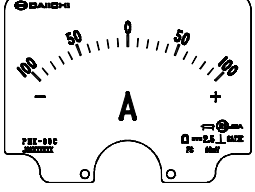
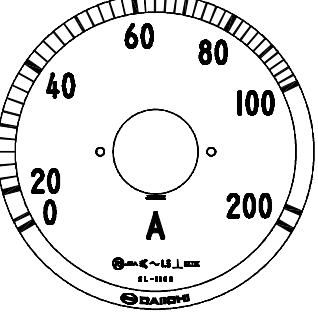
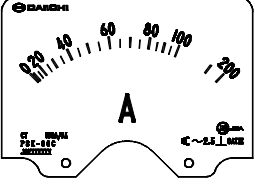
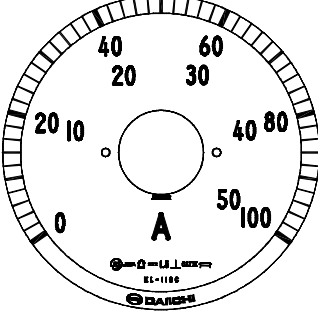
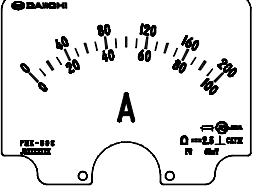
Scale Specification	Wide Angle Meter Ex.: L-110C	Square Shape Meter Ex.: PK-80C
<p>Standard Scale</p> <p>Scale digit: Black Scale line : Black Unit mark : Black Scale division : Refer to standard lancet shape pointer division</p>		
<p>Moving iron type can be left out the lower value part of scale Scale division : Refer to standard lancet shape pointer division</p>		
<p>± Scale Meter (Both Side Deflect Meter)</p> <p>Scale digit: Black Scale line : Black Unit mark : Black</p>		
<p>Extend Scale (2-Fold Extend)</p> <p>Scale digit: Black ; Extend part: Red Scale line : Black ; Extend part: Red Unit mark : Black</p>		
<p>Single Scale Double Seal Meter</p> <p>Scale digit: Black Scale line : Black Unit mark : Black Standard place a seal of scale figure : Higher value will display at inside & smaller value will display at outside</p>		

EX. SCALE

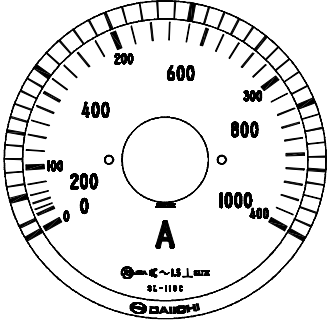
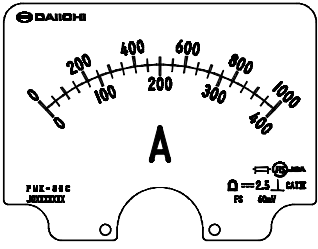
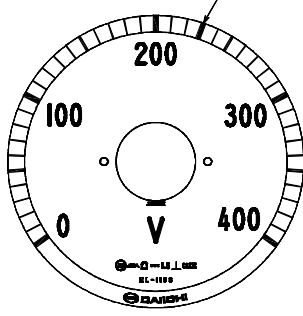
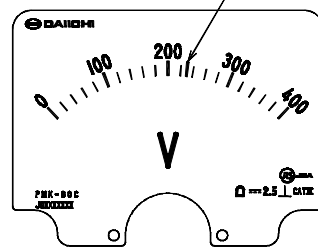
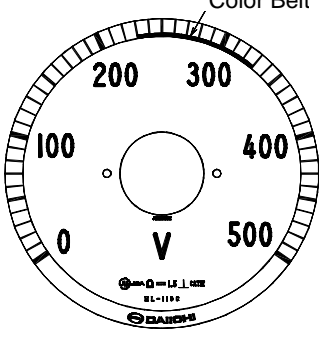
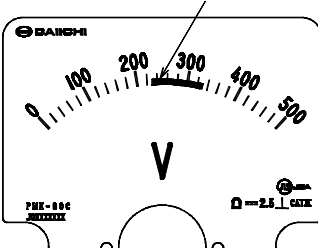
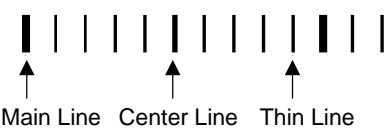
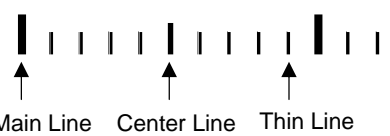
Scale Specification	Wide Angle Meter Ex.: L-110C	Square Shape Meter Ex.: PK-80C
<p>Double Scale Double Seal</p> <p>Scale digit: Black Scale line : Black Unit mark : Black Scale division : Refer to standard lancet shape pointer division Standard place a seal of scale figure : Higher value will display at outside & smaller value will display at inside For wide angle meter : Higher value will display at inside & smaller value will display at outside</p>		
<p>Coloring Scale (Color Line)</p> <p>Scale color line : Red, Yellow, Green Possible combine the color line & color figure to use for double scale</p>		
<p>Color Belt</p> <p>Color Belt : Red, Yellow, Green</p>		
<p>Scale line and Scale figure</p> <p>1) Type of scale line Scale figure will print at main line Please refer to standard lancet shape pointer division & standard knife shape pointer division</p> <p>2) Figure of scale : Max. 4-digit (9999) If 10000 is exceed, unit will be change like 6.6kV or use multiple like $36 \times 1000 \text{min}^{-1}$</p> <p>3) Please have a consultation with us if scale division is different with standard division (odd scale) Please specify for Max. division</p> <p>4) Display 「0」 will be left out if the scale figure after decimal point is Zero. (like scale figure 1 as below)</p> <p>5) Display 「0」 will be left out if the scale figure before decimal point is Zero. (like scale figure 0.5 as below)</p> <p>Ex. : For range value 1.5</p>	 <p>Main Line Center Line Thin Line</p>	 <p>Main Line Center Line Thin Line</p>
	<p>Wide Angle Meter Scale will display by 「1.0」 for wide angle meter (except BRL & RL series)</p>	<p>Square Share Meter BRL & RL series is same scale as square share meter</p>

§ Wide Angle METER §

STANDARD DIVISION OF LANCET-SHAPED POINTER



L series



PK series

MODEL	L-65C PK-60C, 80C, 100C LK-8C, 10C BRL-110CH Instant Meter		RL-80C PK-120C LK-12C F-10	
MAX. SCALE VALUE	SCALE DIVISION DIAGRAM	DIV.	SCALE DIVISION DIAGRAM	DIV.
1		20		20
1.5		30		30
2		20		40
2.5		25		25
3		30		30
4		20		40
5		25		25
6		30		30
7.5		15		37.5
8		16		40
9		18		45

§ Wide Angle METER §



LK series



F series



F series

MODEL	RL-110C BRL-110CH Utility meter		F-15, 17 Note) 4-digit scale of 2T is not manufacturable. L-110C L-80C EL-110C		
	MAX. SCALE VALUE	SCALE DIVISION DIAGRAM	DIV.	SCALE DIVISION DIAGRAM	DIV.
1	*2 0 2 4 6 8 10		50	*2 0 2 4 6 8 10	50
1.5	0 5 10 15		30	*8 0 5 10 15	75
2	*2 0 5 10 15 20		40	0 5 10 15 20	40
2.5	*4 0 5 10 15 20 25		50	0 5 10 15 20 25	50
3	0 10 20 30		30	*8 0 5 10 15 20 25 30	60
4	*2 0 10 20 30 40		40	0 10 20 30 40	40
5	*4 0 10 20 30 40 50		50	0 10 20 30 40 50	50
6	0 20 40 60		30	*8 0 10 20 30 40 50 60	60
7.5	0 20 40 60 75		37.5	I-110 & I-80: 37.5 DIVISION *9 0 20 40 60 75	75
8	0 20 40 60 80		40	0 20 40 60 80	40
9	0 30 60 90		45	*5 0 20 40 60 80 90	45

§ Wide Angle METER §

STANDARD DIVISION OF KNIFE-EDGE POINTER

MODEL	PK-60C, 80C, 100C LK- 8C, 10C FK- 5C,		PK-120C LK- 12C FK- 7C		
	MAX. SCALE VALUE	SCALE DIVISION DIAGRAM	DIV.	SCALE DIVISION DIAGRAM	DIV.
1	0 2 4 6 8 10		50	0 2 4 6 8 10	50
1.5	0 5 10 15		30	0 2 4 6 8 10 12 14 15	75
2	0 5 10 15 20		40	0 5 10 15 20	40
2.5	0 5 10 15 20 25		50	0 5 10 15 20 25	50
3	0 10 20 30		30	0 5 10 15 20 25 30	60
4	0 10 20 30 40		40	0 10 20 30 40	80
5	0 10 20 30 40 50		50	0 10 20 30 40 50	50
6	0 20 40 60		30	0 10 20 30 40 50 60	60
7.5	0 20 60 60 75		37.5	0 20 40 60 75	75
8	0 20 40 60 80		40	0 20 40 60 80	80
9	0 30 60 90		45	0 30 60 90	45

- ▶ Division line part of is omitted for moving iron type meter.
- ▶ For scale extended meter, red color line and numbers of extended part.
- ▶ Have a consultation with us for +/- meter, notation of max. scale value, multiple scale meter, etc.
- ▶ *1, becomes 15 divisions for scale extended ammeter PK-60C, PK-80C and LK-8C.
- ▶ *2, becomes 20 divisions for scale extended ammeter PK-120C, LK-12C, F-10, 15, 17, RL-80C and RL-110C.
- ▶ *3, becomes 15 divisions for scale extended ammeter PK-120C, LK-12C, F-10, 15, 17 and RL-80C.
- ▶ *4, becomes 25 divisions for scale extended ammeter RL-110C.
- ▶ *5, seal numbers: 0, 30, 60, 90 for type meter F-15, and 17.
- ▶ *6, becomes 16 divisions for scale extended ammeter PK-120C, LK-12C, F-10, RL-80C.
- ▶ *7, becomes 18 divisions for scale extended ammeter PK-120C, LK-12C, F-10, RL-80C.
- ▶ *8, becomes 30 divisions for scale extended ammeter F-15, 17.
- ▶ *9, becomes 37.5 divisions for scale extended ammeter F-15, 17.