

## Blizzard SERIES



### Ordering Example

Series Name	Blizzard
Size	50
Max Housing Temperature L = Low H = High	L
Rated Wattage	20W
Heater Voltage	100-240V

### Features

- Dual Voltage 100-240VAC
- UL94V-0 high temperature plastic housing
- Touch safe heater; does not exceed 74°C(165°F) L version/ 105°C(221°F) H version\*
- Optimized for low inrush current
- Self regulating, highest power at low ambient temperature
- Easy Connection, finger guard with integrated terminal block
- Fixing - 35mm DIN-rail mount (EN 50022)

### Options

- Heat Dissipating Diffuser



Type	Blizzard (Natural Convection Heating Element)			
	Blizzard 50L 20W	Blizzard 200L 30W	Blizzard 50H 40W	Blizzard 200H 65W
Nominal Power Output at 10°C (50°F)	20W	30W	40W	65W
Nominal Input Voltage	100 - 240 VAC			
Nominal Input Frequency	50 - 60 Hz			
Maximum Body Temperature ( 25°C Ambient )	74°C (165°F)		105°C (221°F)	
Operating Temperature Range	-30°C to +70°C (-22°F to +158°F)			
Storage Temperature Range	-40°C to +70°C (-40°F to +158°F)			
Dimensions (cross section)	35.3mm x 57mm (1.39" X 2.24")			
Dimensions (length)	97.5mm (3.84")	157.5mm (6.2")	97.5mm (3.84")	157.5mm (6.2")
Connector Block (AWG)	12 - 24			
Weight	100g (3.53oz)	160g (5.64oz)	100g (3.53oz)	160g (5.64oz)
Electrical Protection Class	II			
Ingress Protection (EN60529)	IP 20			
Recommended Fuse (Time-delay)	2A	4A	4A	6.3A
DBK Order No.	11000 11001 (+Diffuser)	11100 11101 (+Diffuser)	11200 11201 (+Diffuser)	11300 11301 (+Diffuser)

Note: All data are for unit operated in vertical orientation.

Example:  
Blizzard 50

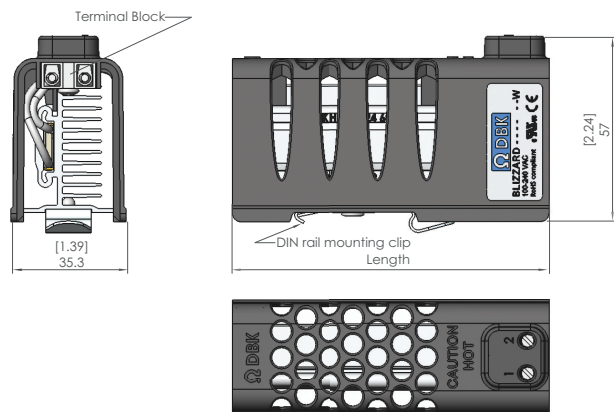

\*in compliance with  
1) Machinery directive 89/392/EEC according to EN 292-1[Clause 3.6.1]  
2) BS 4086:1966 [Clause 3],  
3) BS EN 13202:2000 ref. EN 563

DBK Technology Limited



21/F Harbour Commercial Building  
122 Connaught Rd.C. Sheung Wan, HK

Phone: + 852 2401 1011  
Fax: + 852 2401 7202

hk.sales@dbk-tech.com  
www.dbk-group.de